

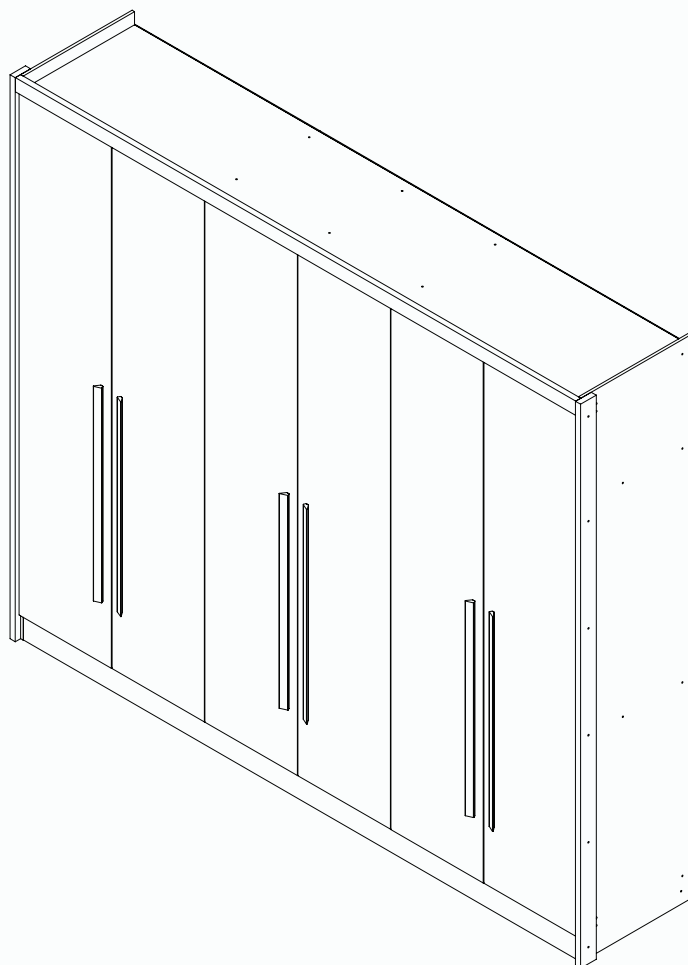

NOVO  
HORIZ  
ONTE

## Manual de montagem Roupeiros Linha 2700 Porta de bater com moldura lateral



Dimensões do produto: sem pés | com pés

Altura:..... 2365mm | 2435mm  
Largura:..... 2762mm | 2762mm  
Profundidade:..... 565mm | 565mm

NOVOHORIZONTE

☎ 32 3539-5050

f moveisnovohorizonte

📷 moveis.novo.horizonte

🌐 [www.moveisnovohorizonte.com.br](http://www.moveisnovohorizonte.com.br)

✓ Atualizado em:  
09/05/2023

# LISTA DE PEÇAS

N°	Código	Descrição	Dimensões (mm)			Quantidade
			Comprimento	Largura	Espessura	
1	12772	RODAPE FRONTAL	2688	110	15	1
2	13925	RODAPE TRASEIRO	2688	110	15	1
3	6866	TRAVESSA DO RODAPÉ	461	109	15	2
4	14463	BASE	2688	540	12	1
5	14395	LATERAL DIREITA	2364	540	12	1
6	6850	PRATELEIRA GAVETA	888	430	15	2
7	14465	DIVISÃO DIREITA	2175	540	12	1
8	14466	DIVISÃO CENTRAL	2175	435	12	1
9	14437	DIVISÃO ESQUERDA	2175	540	12	1
10	14396	LATERAL ESQUERDA	2364	540	12	1
11	14476	PRATELEIRA MENOR	438	430	15	4
12	14475	PRATELEIRA DO MALEIRO	888	430	15	2
13	14464	TAMPO	2688	540	12	1
14	14468	MOLDURA SUPERIOR	2712	60	25	1
15	14461	MOLDURA LATERAL	2364	75	25	2
16	14467	COSTAS	2200	902	3	3
17	8099	PORTA	2190	447	15	6
18	14479	FRENTE DE GAVETA	814	170	15	4/6/8*
19	14381	LATERAL DE GAVETA	400	130	12	8/12/16*
20	14492	FUNDO DE GAVETA	790	403	3	4/6/8*
21	12769	TRASEIRO DE GAVETA	776	130	15	4/6/8*
22	9747	ESPELHO (OPCIONAL)	710	330	3	6

**\*QUANTIDADE VARIADA DE ACORDO COM O KIT DE GAVETAS ESCOLHIDO: 4, 6 OU 8 GAVETAS.**

## VISTA EXPLODIDA

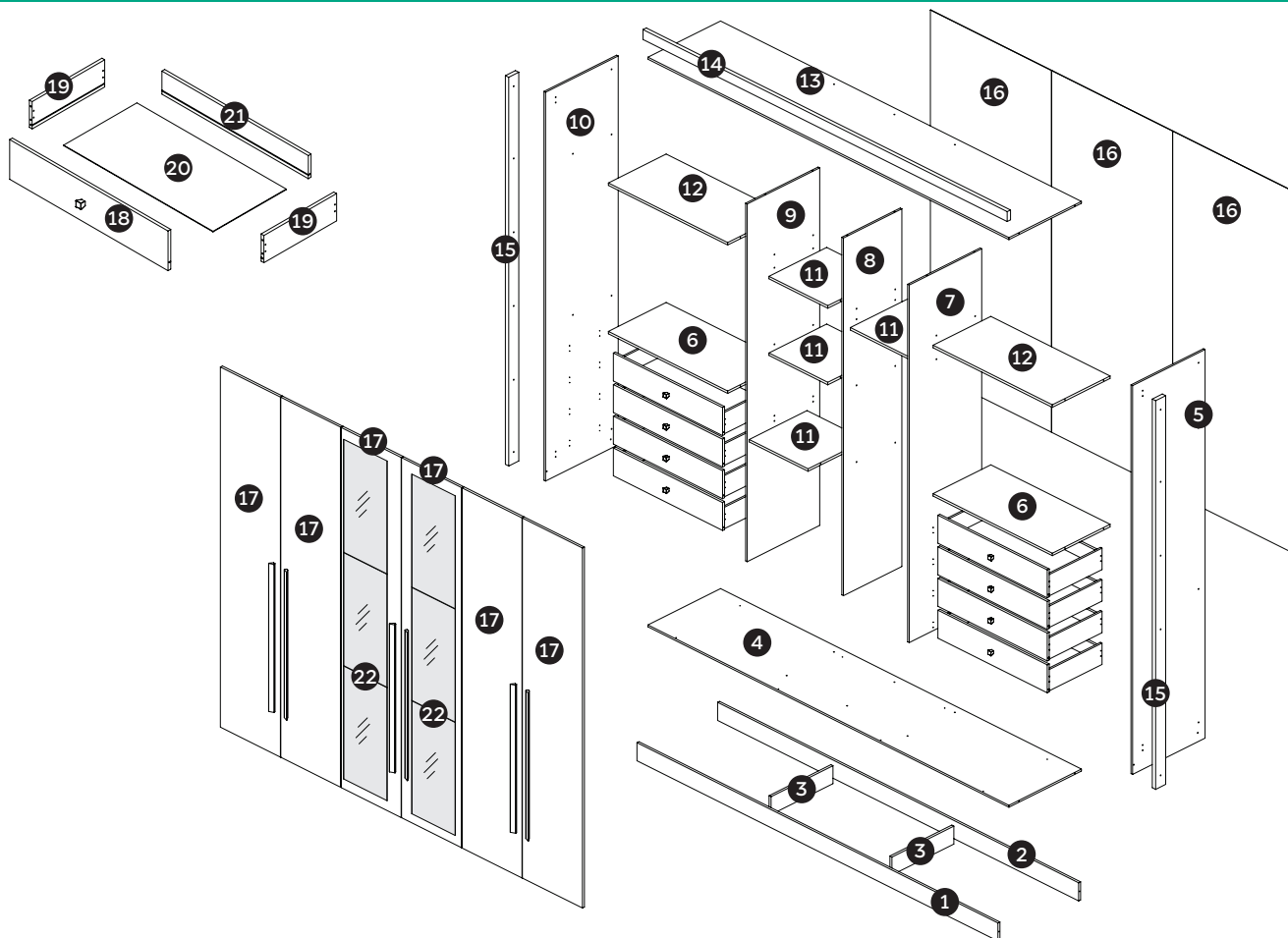

# LISTA DE PEÇAS







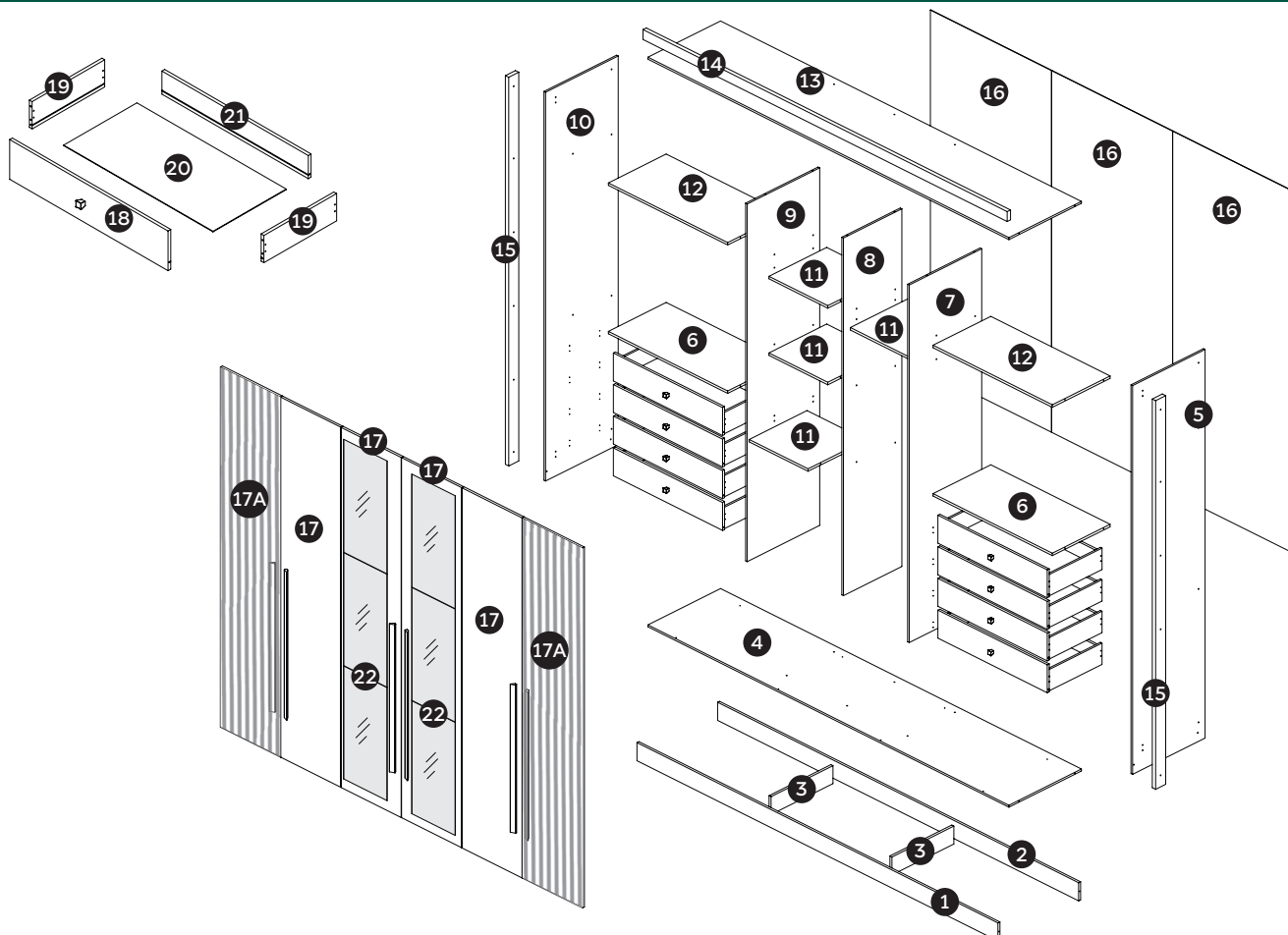











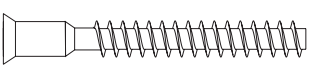
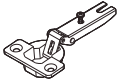
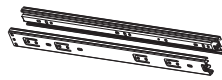

N°	Código	Descrição	Dimensões (mm)			Quantidade
			Comprimento	Largura	Espessura	
1	12772	RODAPE FRONTAL	2688	110	15	1
2	13925	RODAPE TRASEIRO	2688	110	15	1
3	6866	TRAVESSA DO RODAPÉ	461	109	15	2
4	14463	BASE	2688	540	12	1
5	14395	LATERAL DIREITA	2364	540	12	1
6	6850	PRATELEIRA GAVETA	888	430	15	2
7	14465	DIVISÃO DIREITA	2175	540	12	1
8	14466	DIVISÃO CENTRAL	2175	435	12	1
9	14437	DIVISÃO ESQUERDA	2175	540	12	1
10	14396	LATERAL ESQUERDA	2364	540	12	1
11	14476	PRATELEIRA MENOR	438	430	15	4
12	14475	PRATELEIRA DO MALEIRO	888	430	15	2
13	14464	TAMPO	2688	540	12	1
14	14468	MOLDURA SUPERIOR	2712	60	25	1
15	14461	MOLDURA LATERAL	2364	75	25	2
16	14467	COSTAS	2200	902	3	3
17	8099	PORTA	2190	447	15	4
17A	13725	PORTA COM PINTURA RIPADA	2190	447	15	2
18	14479	FRENTE DE GAVETA	814	170	15	4/6/8*
19	14381	LATERAL DE GAVETA	400	130	12	8/12/16*
20	14492	FUNDO DE GAVETA	790	403	3	4/6/8*
21	12769	TRASEIRO DE GAVETA	776	130	15	4/6/8*
22	9747	ESPELHO (OPCIONAL)	710	330	3	6

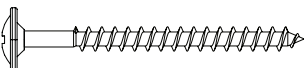
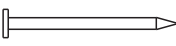

**\*QUANTIDADE VARIADA DE ACORDO COM O KIT DE GAVETAS ESCOLHIDO: 4, 6 OU 8 GAVETAS.**

## VISTA EXPLODIDA

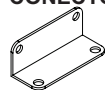

# LISTA DE FERRAGENS E ACESSÓRIOS

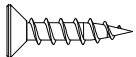
<b>A1 - CAVILHA MADEIRA 6X30 *28/36/44</b>  CÓD.: 1404	<b>C2 - SAPATA PLÁSTICA</b> <b>08</b>  CÓD.: 1117	<b>I2 - COLA 10g.</b> <b>01</b>  CÓD.: 1472
<b>B2 - PARAFUSO 3,5X25 FLANGEADO</b> <b>18</b>  CÓD.: 2859	<b>C5 - DISTANCIADOR PLÁSTICO *16/24/32</b>  CÓD.: 16671	<b>I3 - GIZ PARA RETOQUE</b> <b>01</b>  CÓD.: 1158
<b>B3 - PARAFUSO 3,5X35 CABEÇA CHATA</b> <b>*36/44/52</b>  CÓD.: 1422	<b>D1 - CALÇO DOBRADIÇA 3MM</b> <b>18</b>  CÓD.: 3879	<b>I4 - SUPORTE CABIDEIRO</b> <b>08</b>  CÓD.: 2051
<b>B4 - PARAFUSO 5,0X40</b> <b>44</b>  CÓD.: 2272	<b>D2 - DOBRADIÇA 35MM</b> <b>18</b>  CÓD.: 1409	<b>J1 - PAR CORREDIÇA *04/06/08</b>  CÓD.: 5357
<b>B6 - PARAFUSO 4,0X12 CABEÇA CHATA</b> <b>*183/207/231</b>  CÓD.: 16998	<b>E1 - TAPA FURO ADESIVO 17MM</b> <b>36</b>  CÓD.: 12342	<b>K3 - PUXADOR</b> <b>*04/06/08</b>  CÓD.: 16020
<b>B9 - PARAFUSO 4X40MM</b> <b>*16/24/32</b>  CÓD.: 7066	<b>F1 - PREGO 10X10</b> <b>150</b>  CÓD.: 1474	<b>K4 - PUXADOR MDF 900mm</b> <b>06</b>  CÓD.: 14268
<b>B10 - PARAFUSO 3,5X30 FLANGEADO S/PONTA</b> <b>*04/06/08</b>  CÓD.: 2858	<b>G2 - FIXADOR DE COSTAS</b> <b>30</b>  CÓD.: 14421	<div style="border: 1px solid red; border-radius: 15px; padding: 10px; text-align: center;">   <b>*QUANTIDADE VARIADA DE ACORDO COM O KIT DE GAVETAS ESCOLHIDO: 4, 6 OU 8 GAVETAS</b> </div>
<b>B12 - PARAFUSO 4,0X16 FLANGEADO</b> <b>*32/48/64</b>  CÓD.: 10251	<b>H3 - TUBO CABIDEIRO 880mm</b> <b>02</b>  CÓD.: 6975	
<b>C1 - CONECTOR 4 FUROS</b> <b>*17/21/25</b>  CÓD.: 1453	<b>H4 - TUBO CABIDEIRO 428mm</b> <b>02</b>  CÓD.: 7879	

KIT OPCIONAL ESPELHOS	
<b>B16 - PARAFUSO 3,5X16</b> <b>12</b>  CÓD.: 1426	
<b>C8 - SUPORTE P/ ESPELHO</b> <b>12</b>  CÓD.: 4003	

8747 - KIT OPCIONAL PÉS	
<b>B17 - PARAFUSO 3,5X12 FLANGEADO</b> <b>32</b>  CÓD.: 2042	
<b>C7 - PÉ P/ ROUPEIRO 70X70mm</b> <b>08</b> 	

Cores e código para assistência técnica

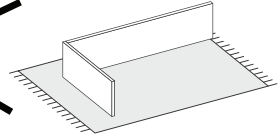
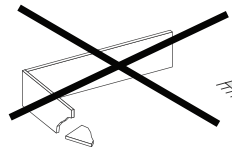
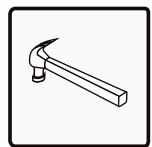
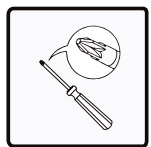
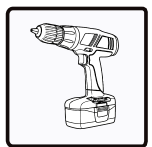

As ferramentas necessárias para montagem do produto não são fornecidas.

Utilize um tapete ou a própria embalagem do produto como proteção para realizar a montagem.

Utilize a régua para medir os componentes | Medidas em mm.

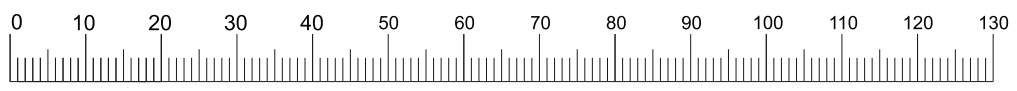

# 01

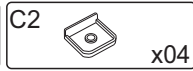
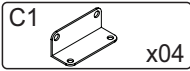
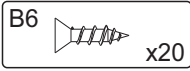

 Verificar se o 'KIT DE PÉS' foi adquirido. Se sim, não montar o item C2 nessa etapa.

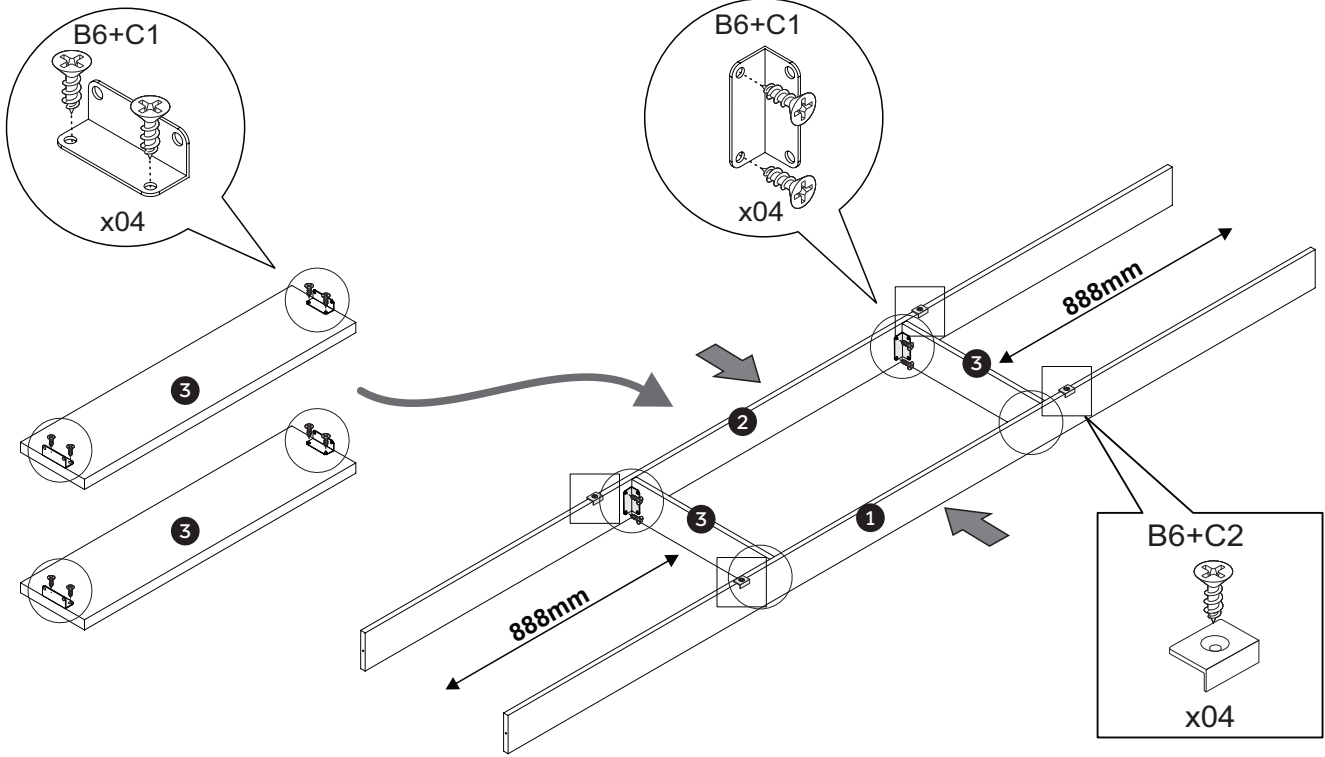



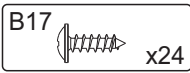

# 02

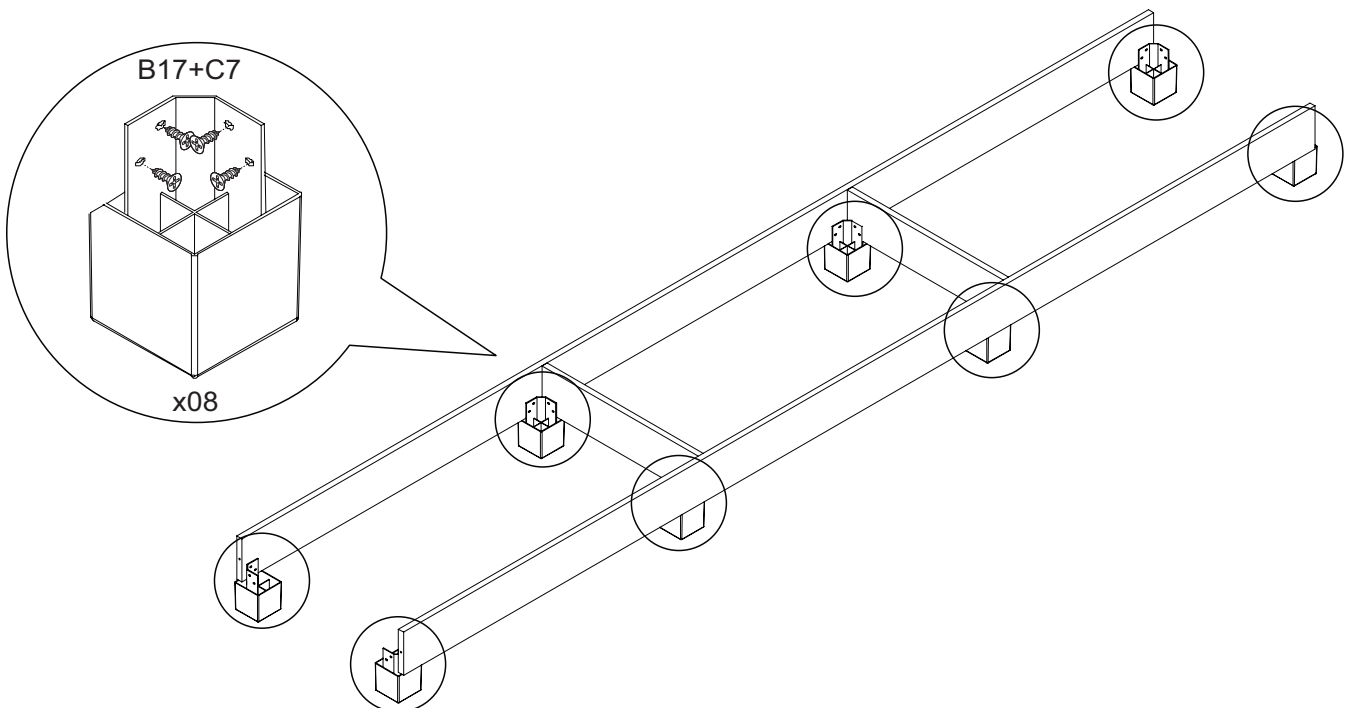

**ETAPA OPCIONAL.**  
Apenas para quando o 'KIT PÉS' tiver sido adquirido.



### 03

B6		x04	C2		x04
B12		*x32 *x48 *x64	C5		*x16 *x24 *x32



\*QUANTIDADE VARIADA DE ACORDO COM O KIT DE GAVETAS ESCOLHIDO: 4, 6 OU 8 GAVETAS

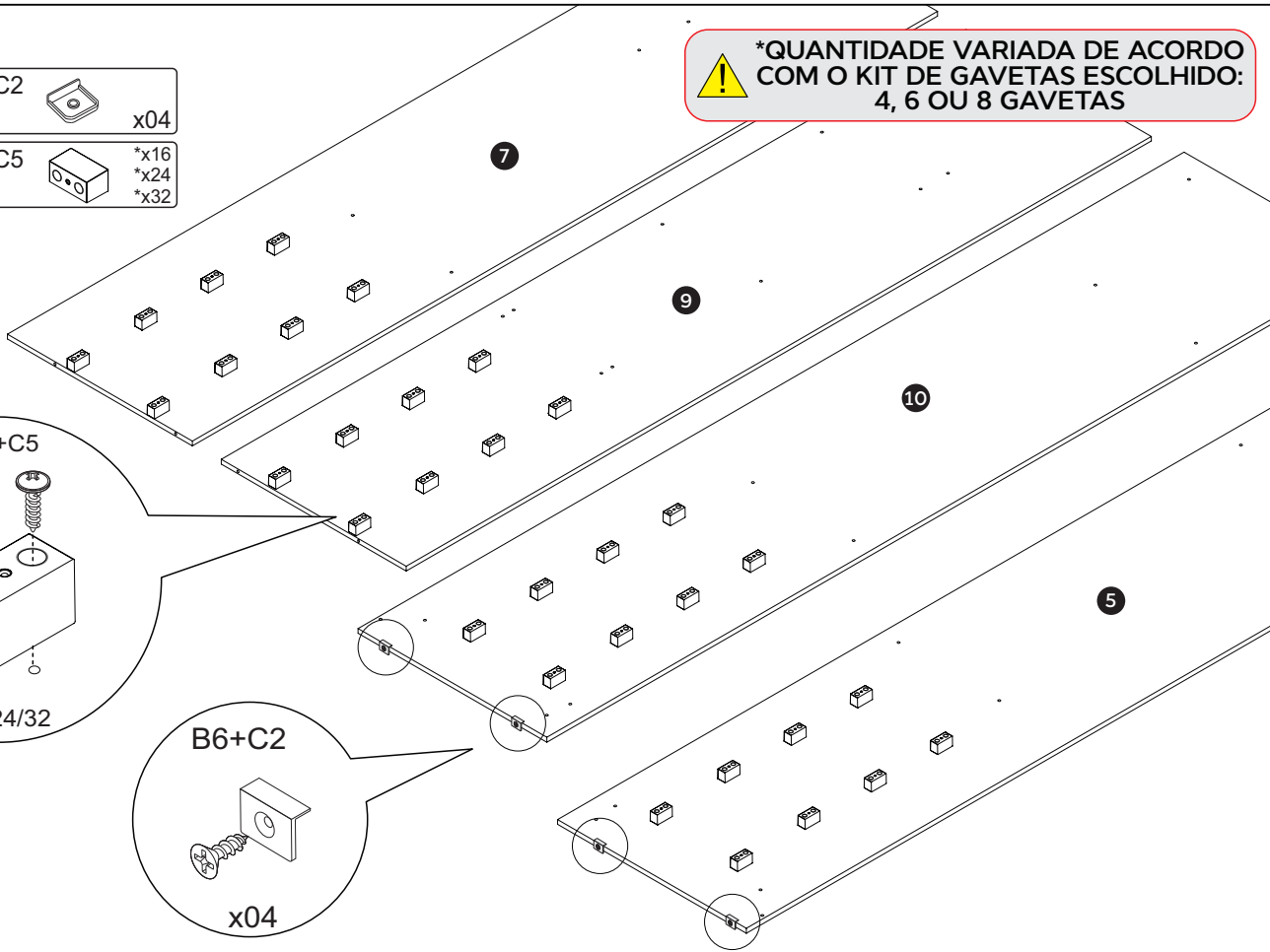
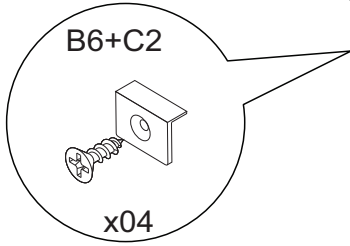
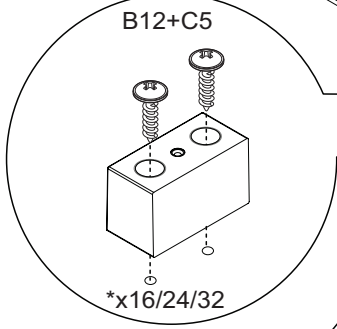

### 04

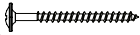
J1		*x04 *x06 *x08	B9		*x16 *x24 *x32
----	--	----------------------	----	---	----------------------

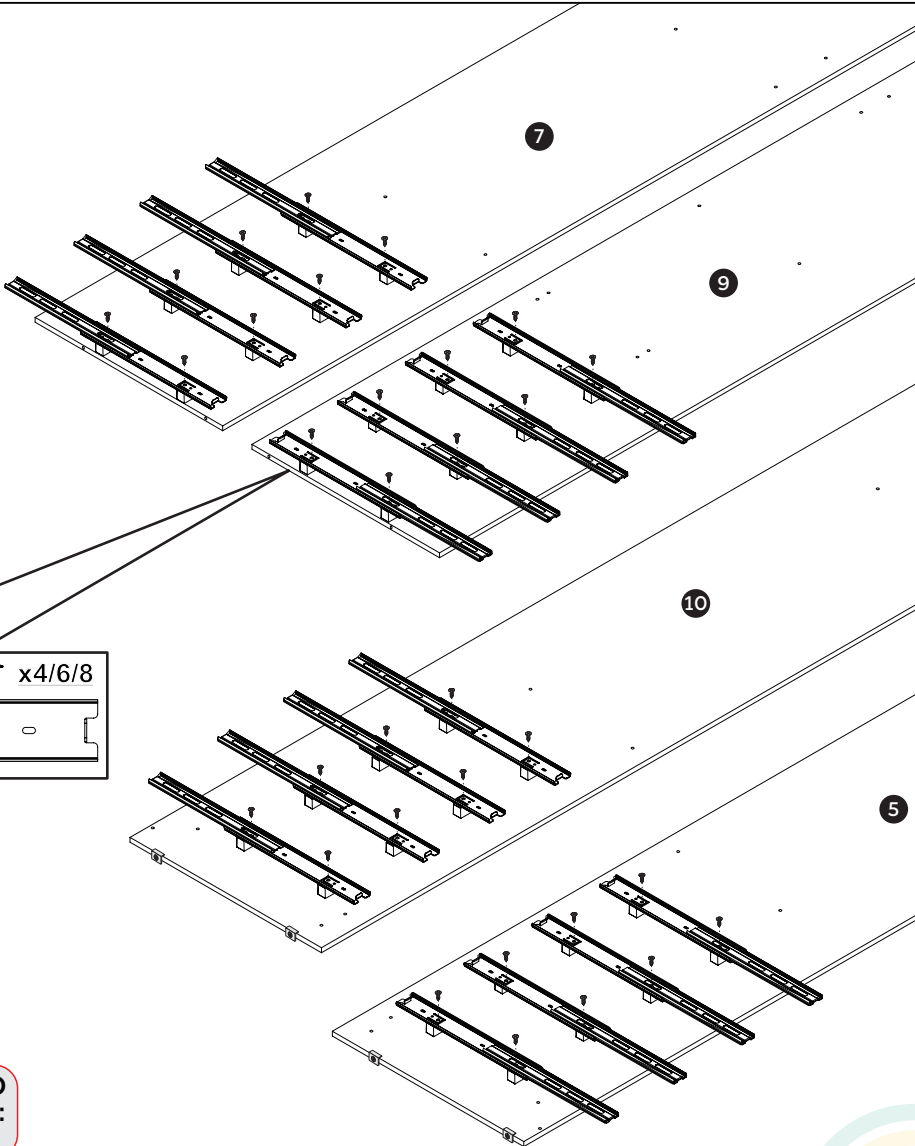
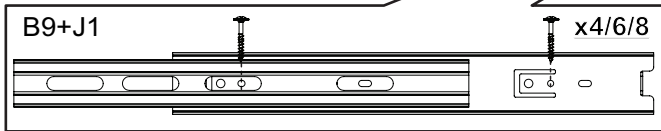
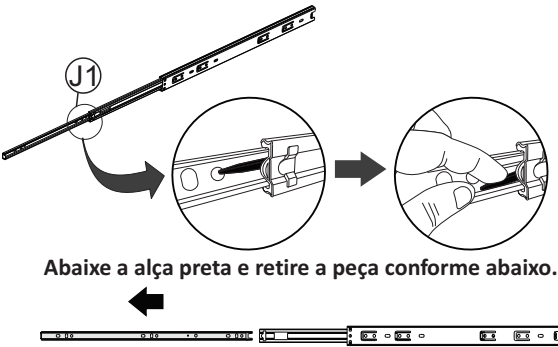

\*QUANTIDADE VARIADA DE ACORDO COM O KIT DE GAVETAS ESCOLHIDO: 4, 6 OU 8 GAVETAS

05

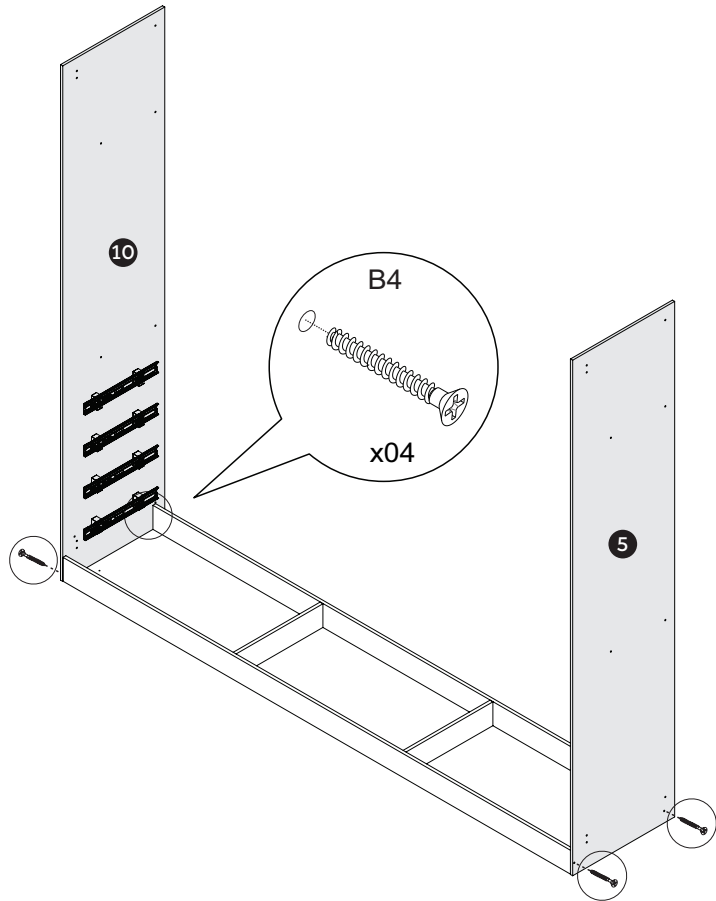

05.1

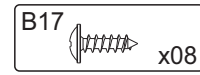

ETAPA OPCIONAL.  
Apenas para quando o 'KIT PÉS'  
tiver sido adquirido.

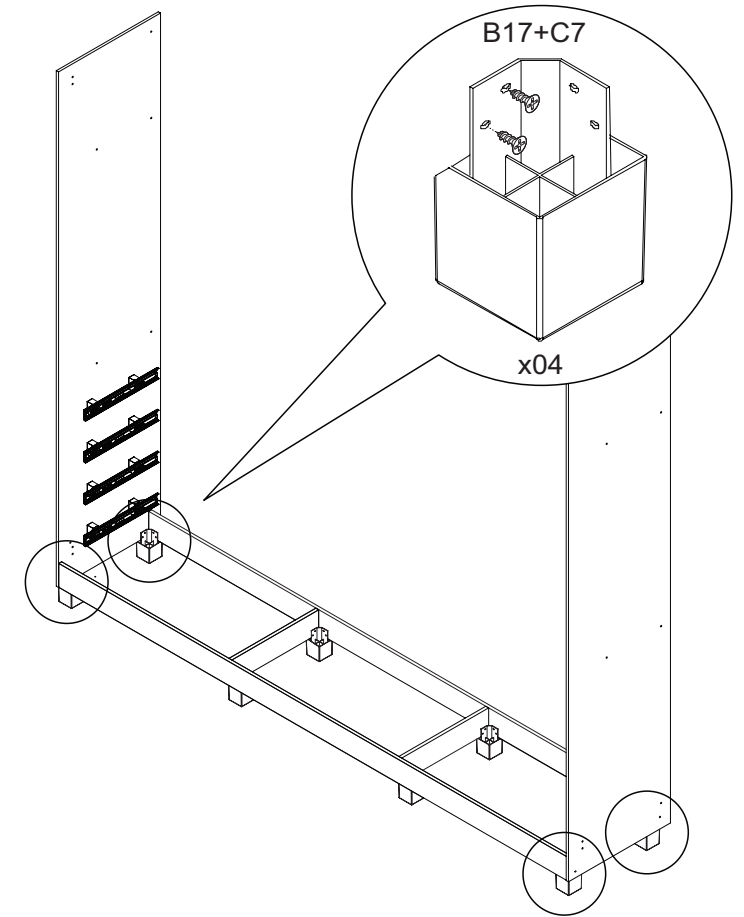

06

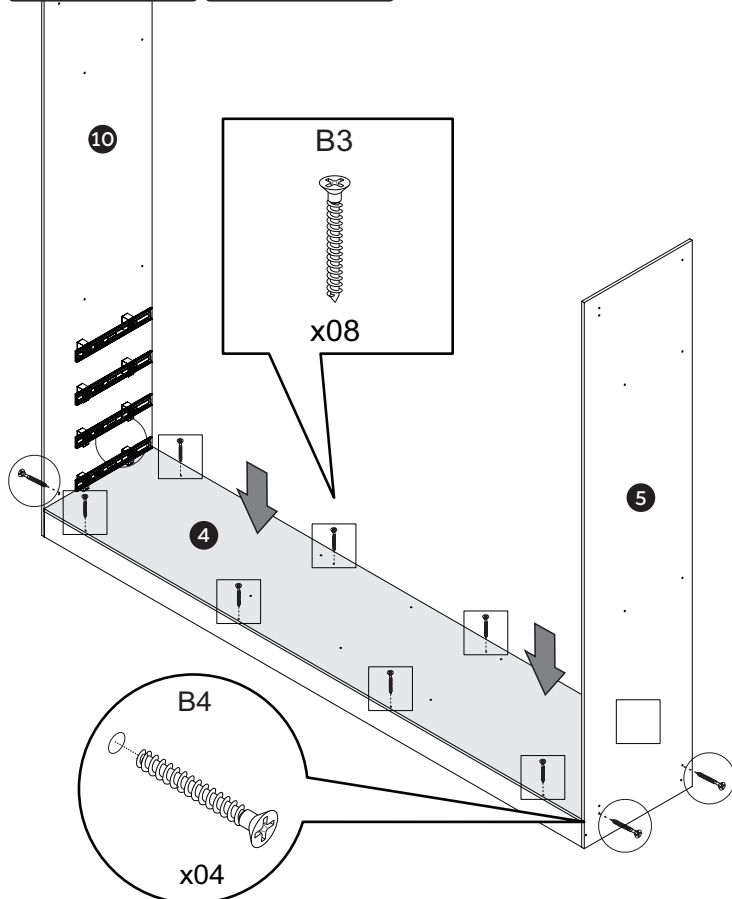
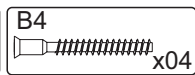
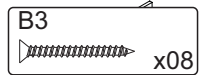

07

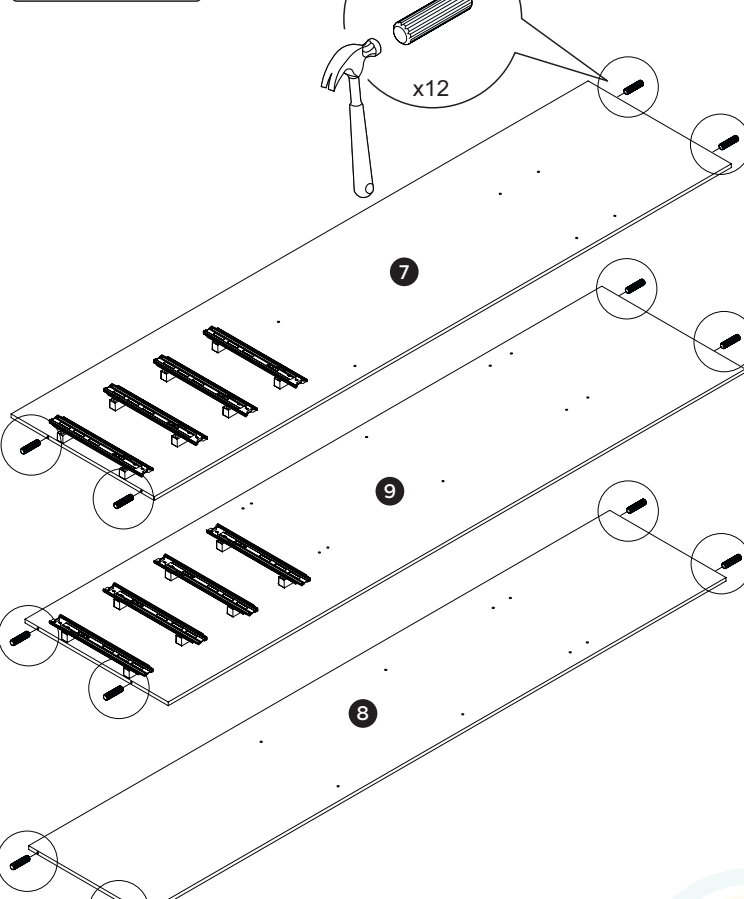

08

B4  
x08

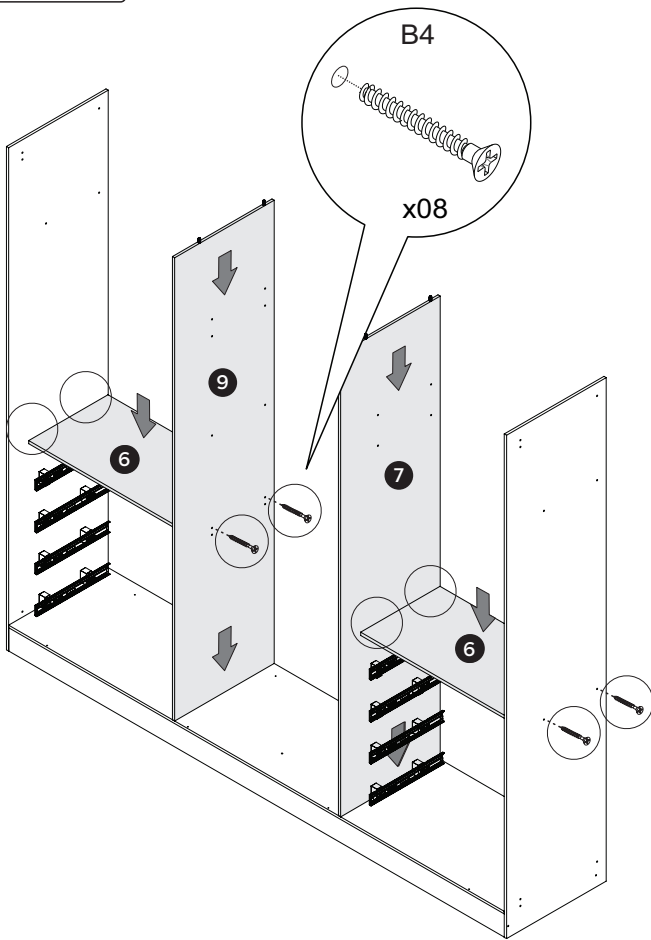

09

B4  
x16

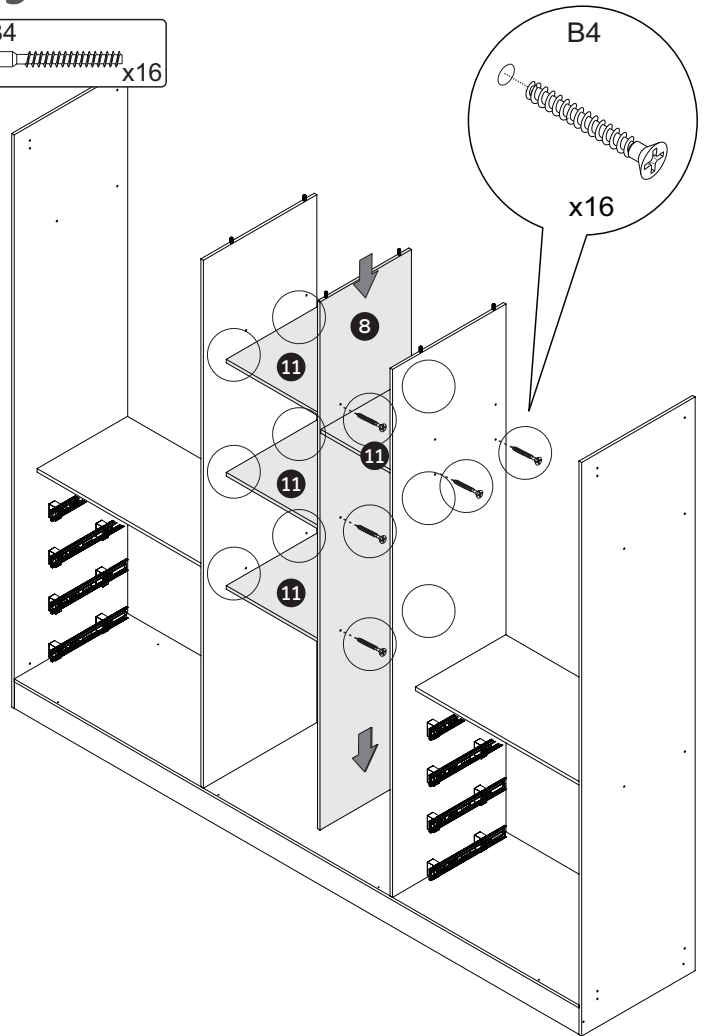

10

B4  
x08

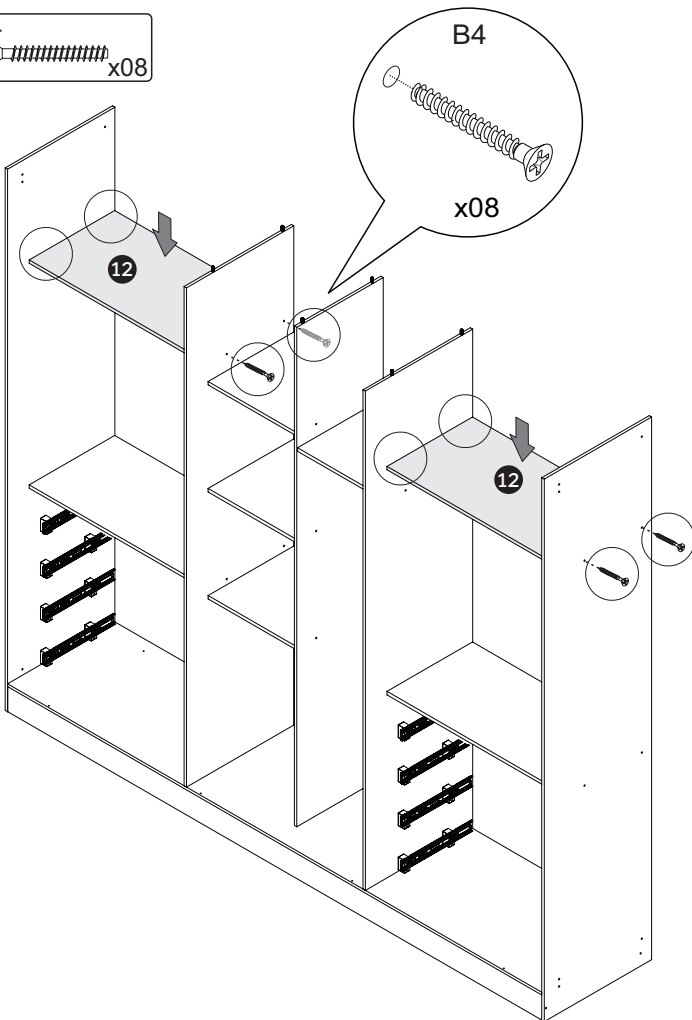

11

B6  
x20

C1  
x05

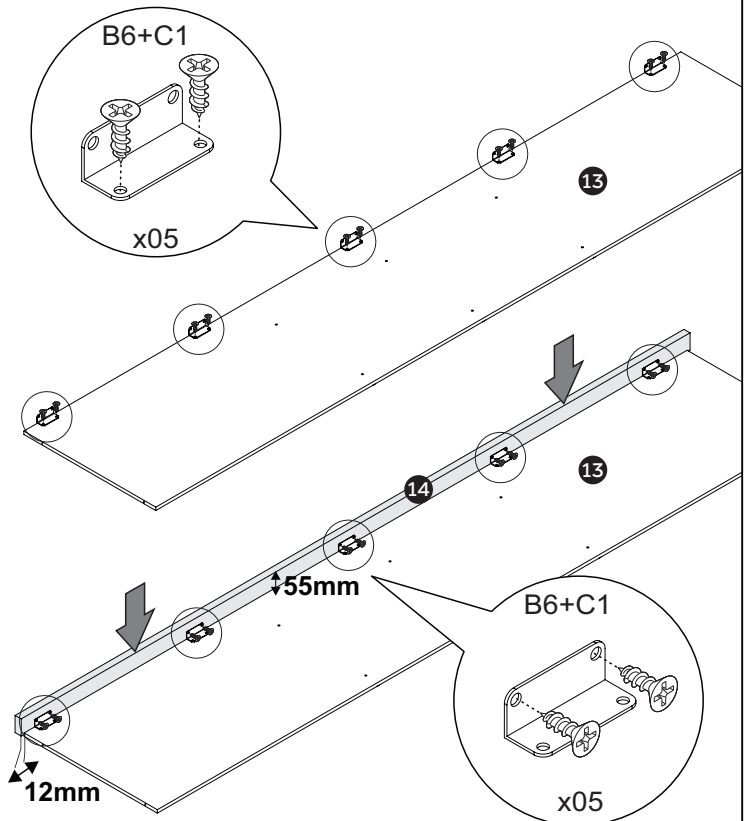

⚠ Fixar a moldura com 55mm de distância conforme detalhe.

12

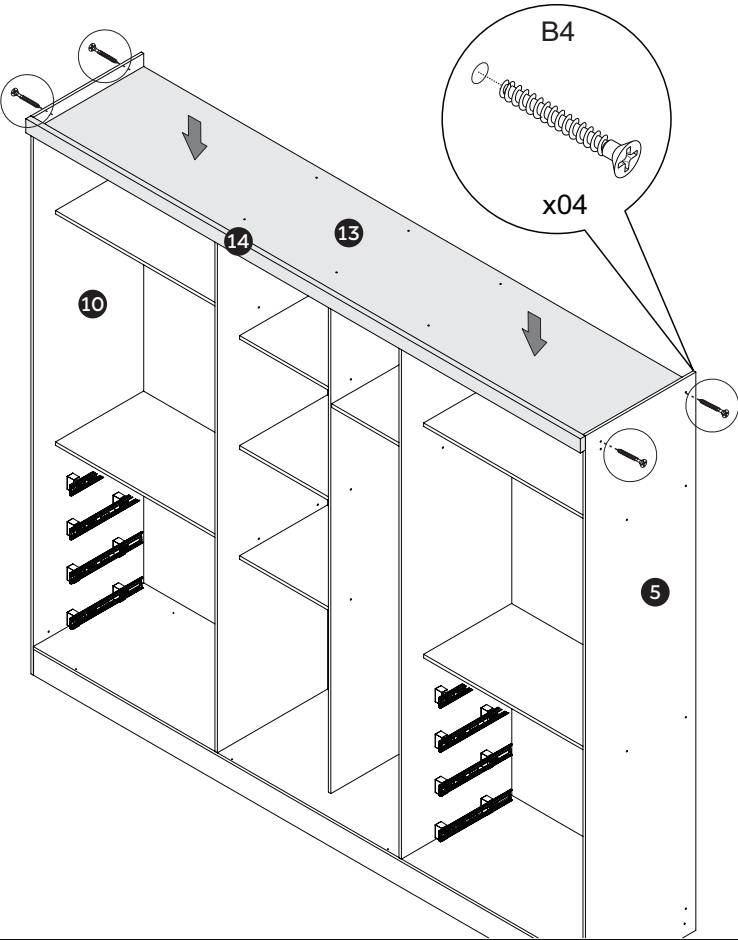
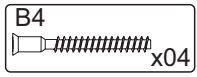

13

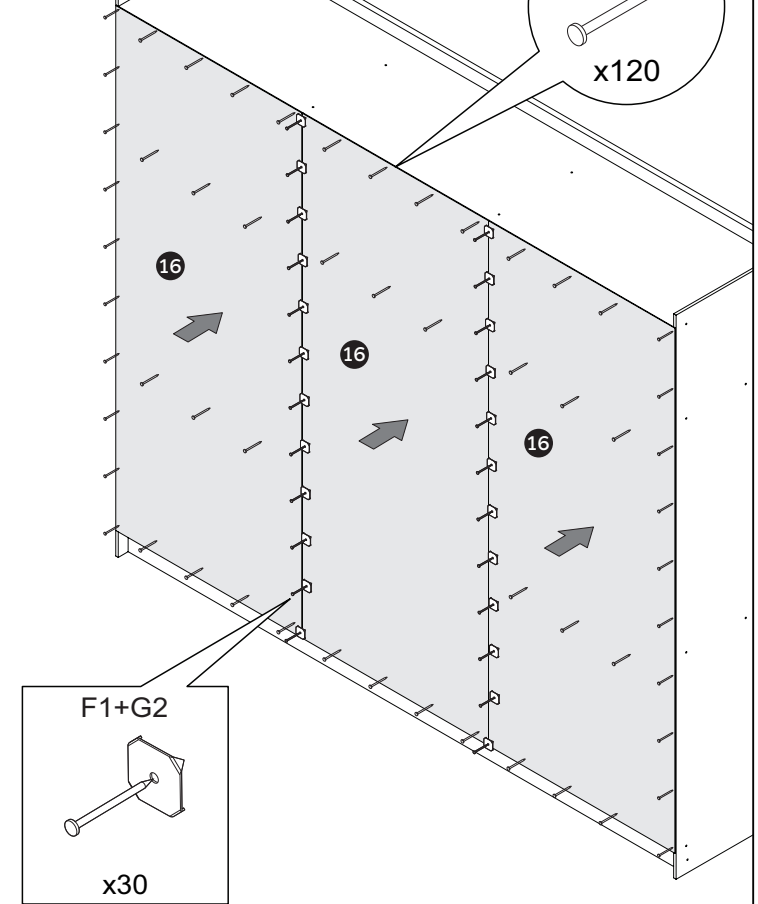
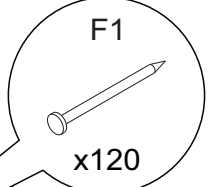
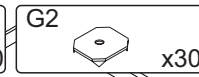
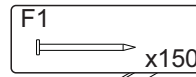

14

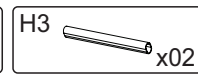
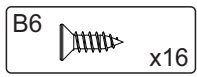

 Encaixar os tubos (H3 e H4) nos suportes.

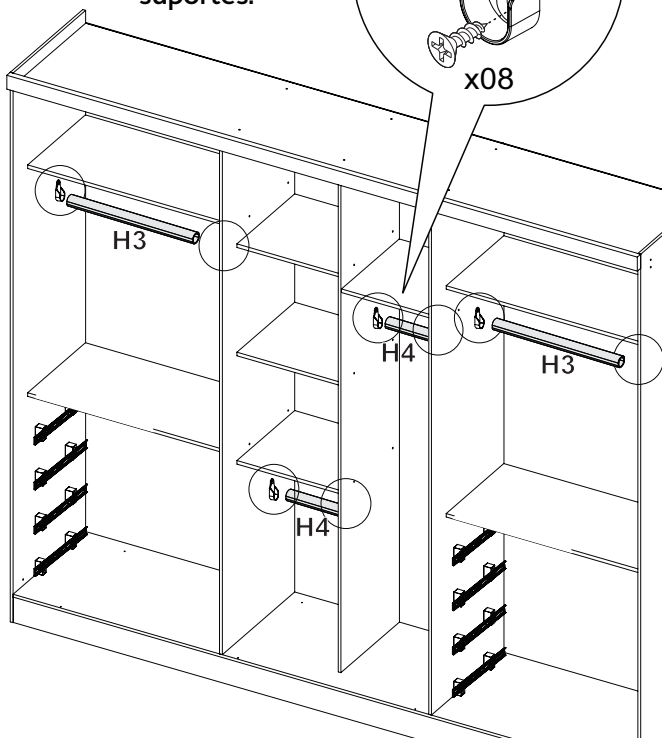
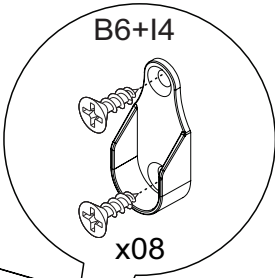

15

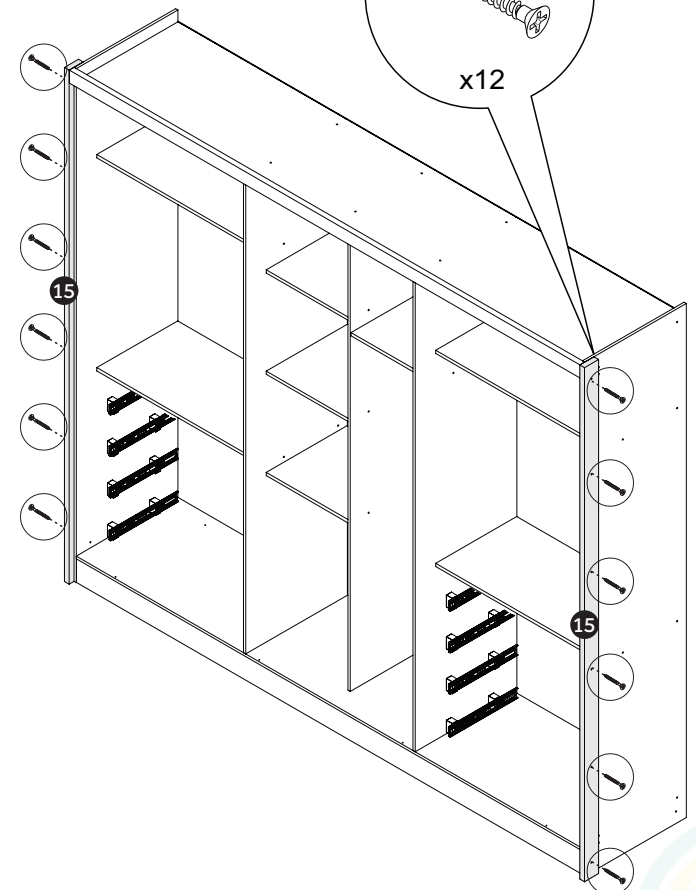
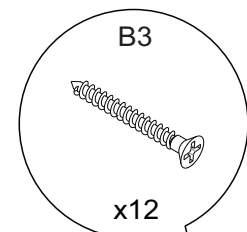
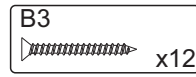

## 16 REPETIR ESTA ETAPA 6x.

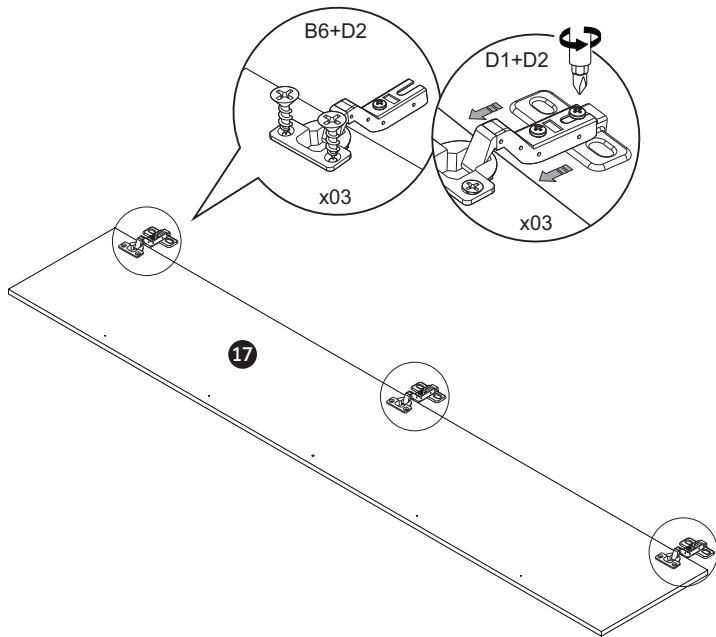
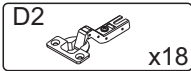
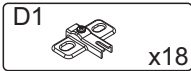
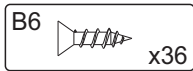

## 16.1

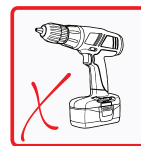
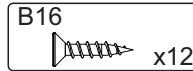

**ETAPA OPCIONAL.**  
Apenas para quando o 'KIT ESPELHO' tiver sido adquirido.

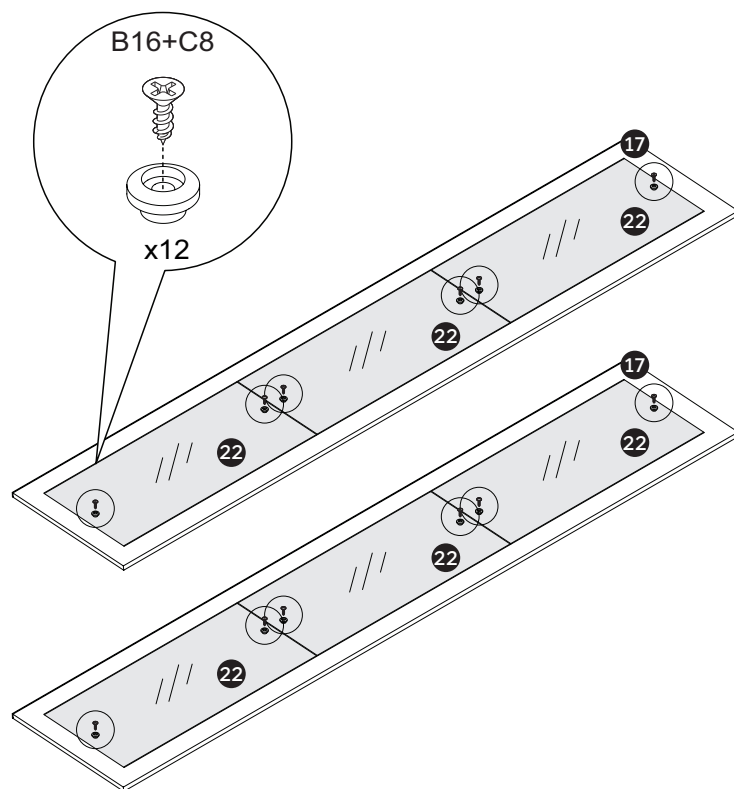

## 17

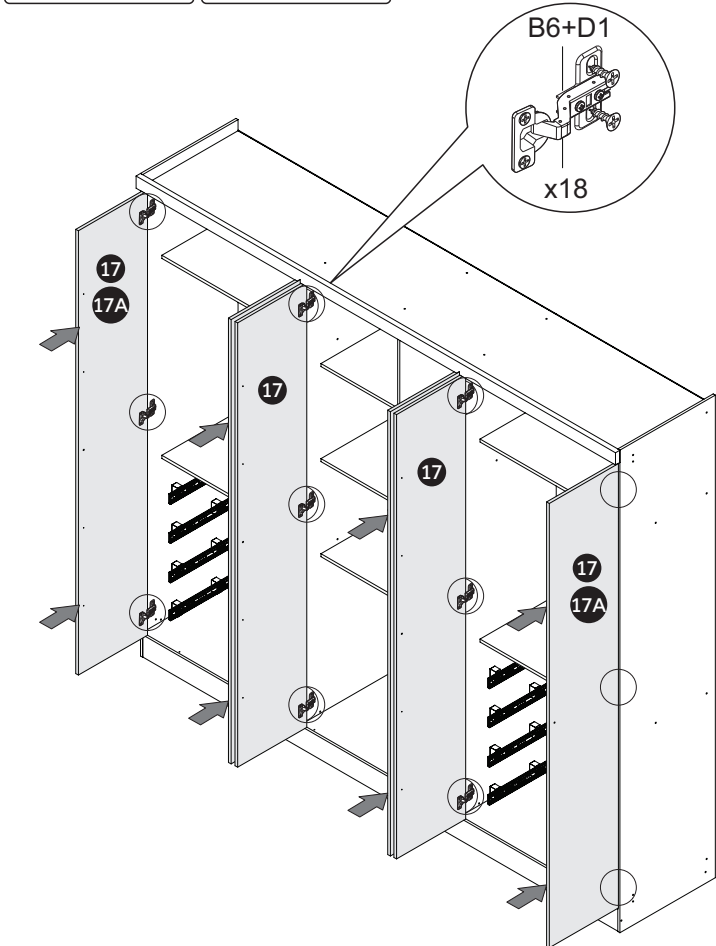
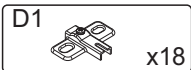
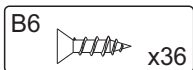

## 18

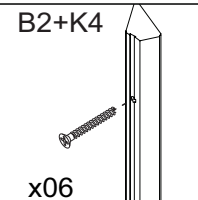
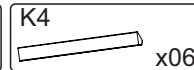
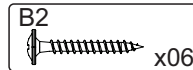

**!** Fixar o puxador no furo central da porta.

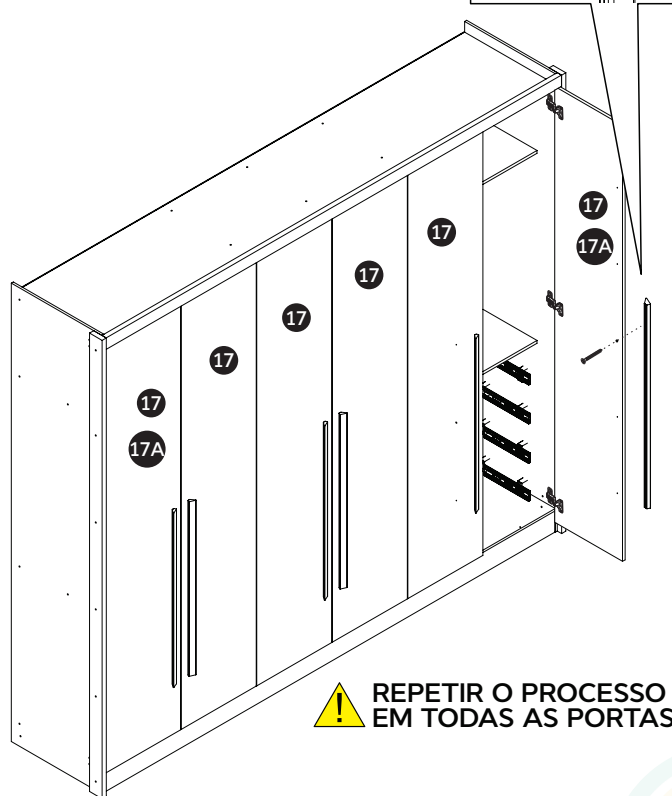

**!** REPETIR O PROCESSO EM TODAS AS PORTAS.

19



Terminar a furação correspondente a fixação do puxador. Depois, fixar o outro parafuso do puxador.

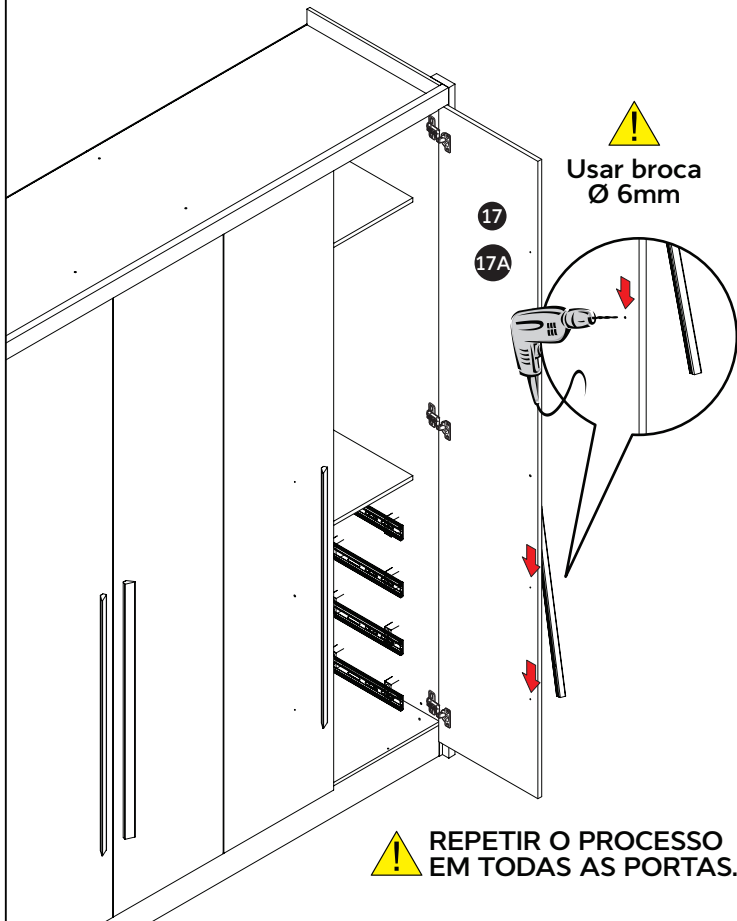

20

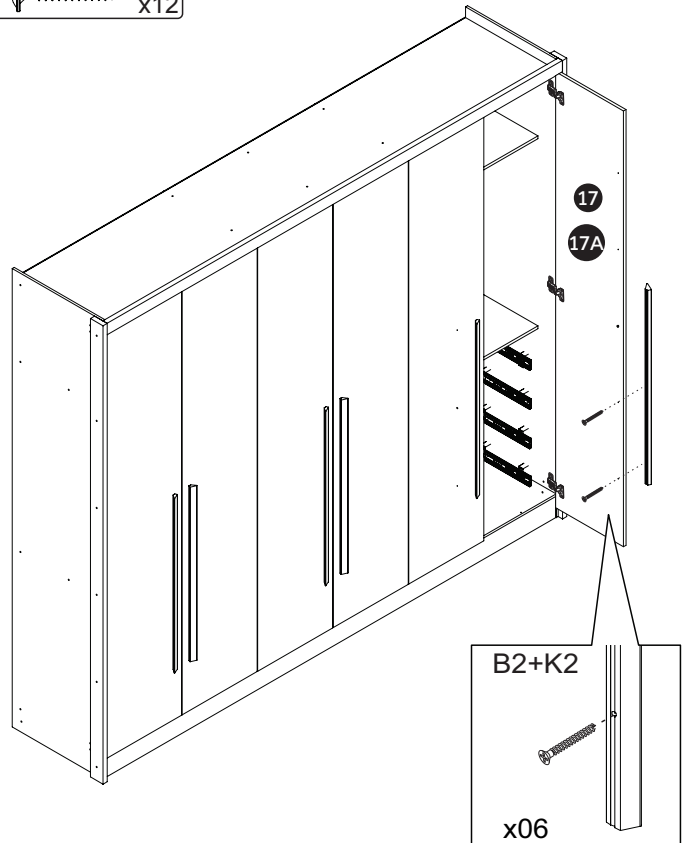

21 REPETIR ESTA ETAPA 4/6/8x.

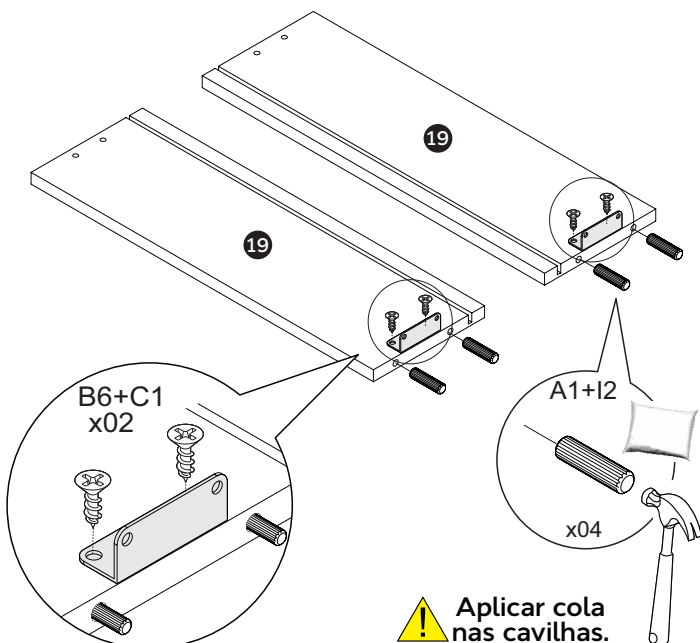
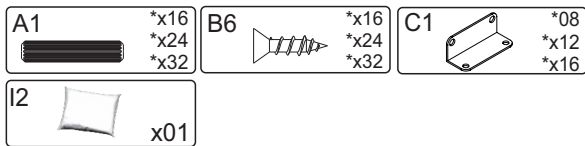

22 REPETIR ESTA ETAPA 4/6/8x.

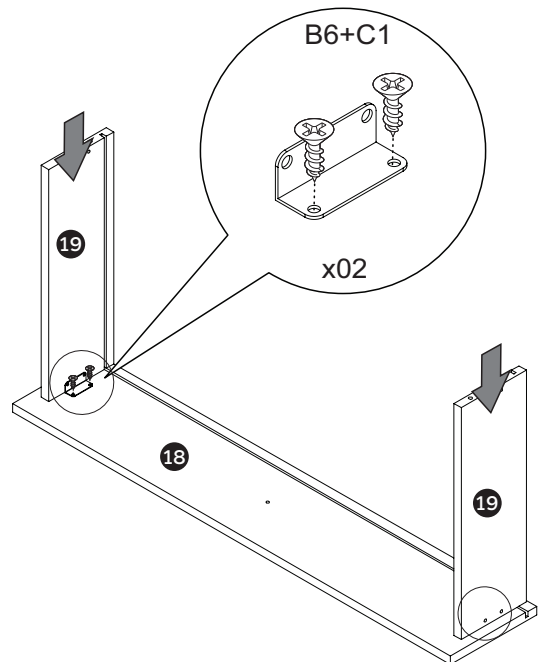
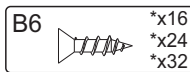

\*QUANTIDADE VARIADA DE ACORDO COM O KIT DE GAVETAS ESCOLHIDO: 4, 6 OU 8 GAVETAS



\*QUANTIDADE VARIADA DE ACORDO COM O KIT DE GAVETAS ESCOLHIDO: 4, 6 OU 8 GAVETAS

### 23 REPETIR ESTA ETAPA 4/6/8x.

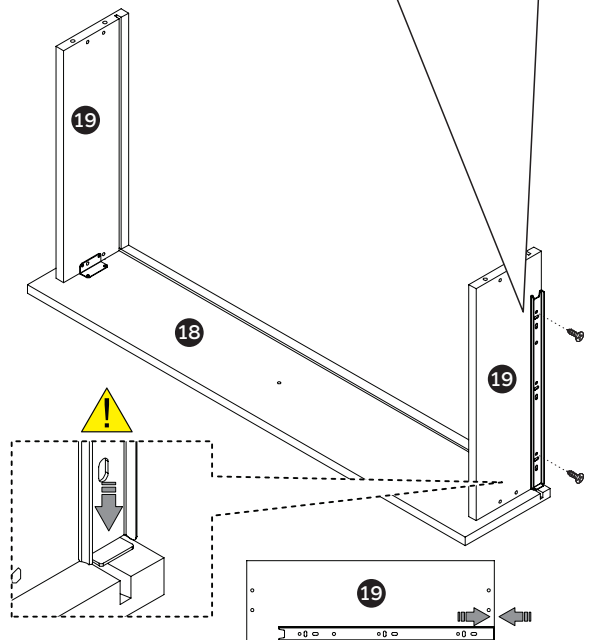
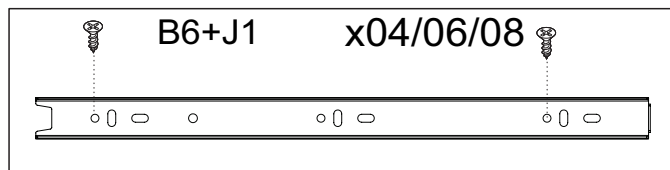
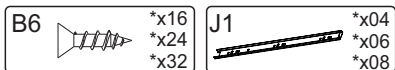

Alinhar a correia com o topo da peça 19.

### 24 REPETIR ESTA ETAPA 4/6/8x.

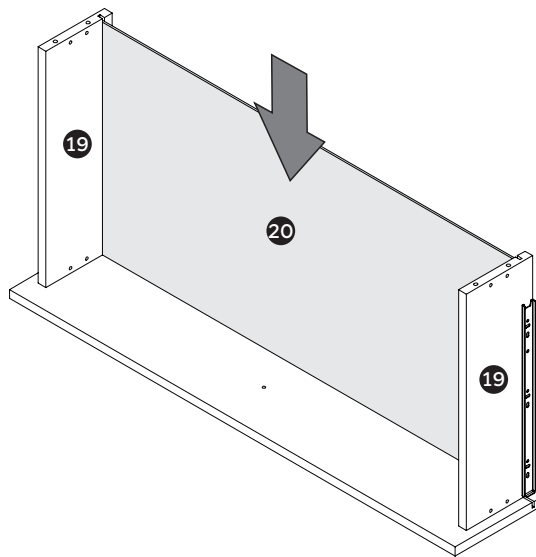

### 25 REPETIR ESTA ETAPA 4/6/8x.

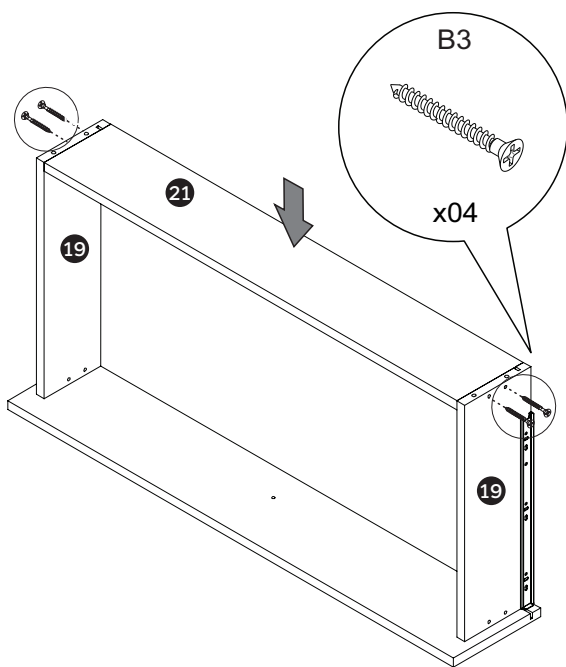
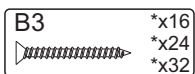

\*QUANTIDADE VARIADA DE ACORDO COM O KIT DE GAVETAS ESCOLHIDO: 4, 6 OU 8 GAVETAS

### 26 REPETIR ESTA ETAPA 4/6/8x.

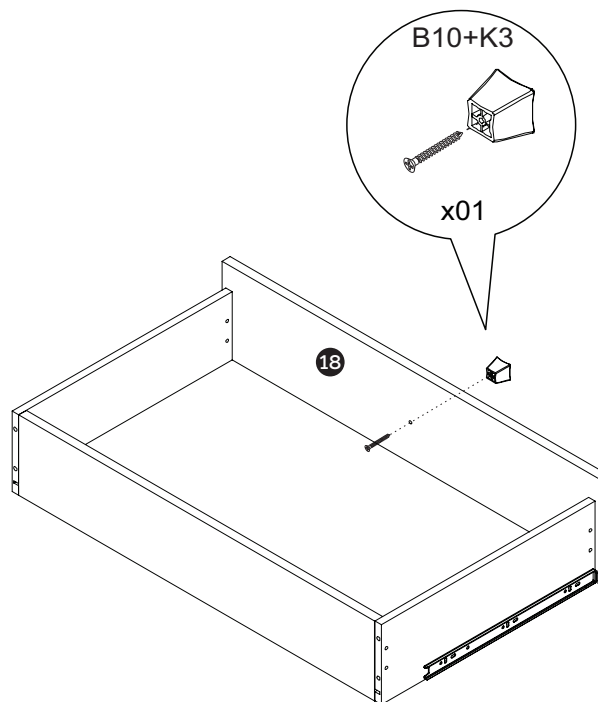
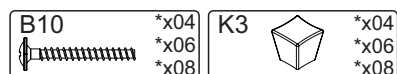

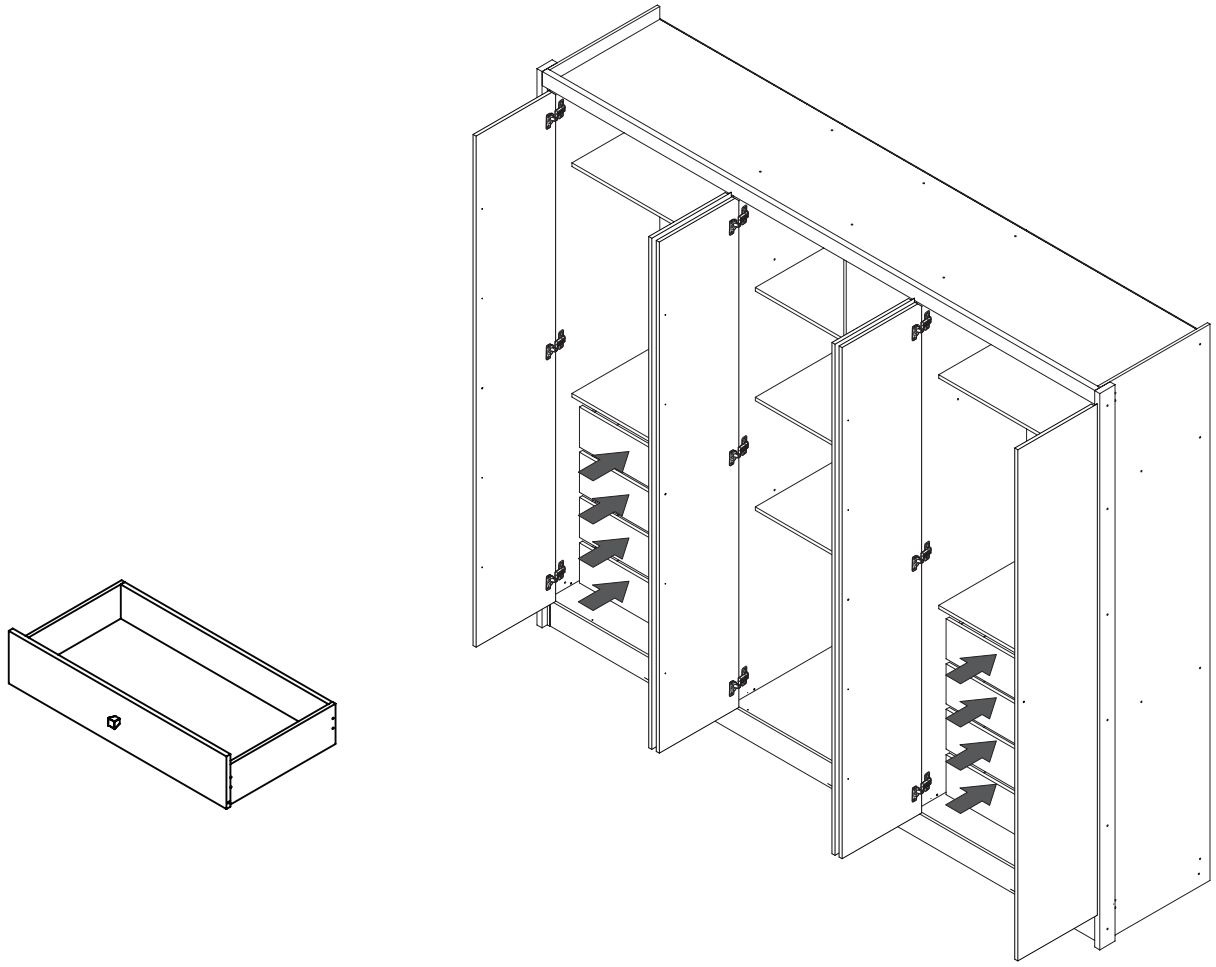

\*QUANTIDADE VARIADA DE ACORDO COM O KIT DE GAVETAS ESCOLHIDO: 4, 6 OU 8 GAVETAS

## 27 INSERIR AS GAVETAS

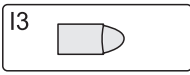
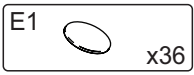

## 28



 Usar o giz para retocar pequenos detalhes.

