

Item	Caixa Caja Box	Qtd Ctd Qty	Descrição Descripción Description	Medidas (mm) Dimensiones (mm) Size (measurements) (mm)
51	3/3	01	Porta menor paneleiro Puerta más pequeña despensero Paneleiro smaller door	628x329x15
52	3/3	01	Porta maior paneleiro Puerta más grande despensero Larger Door Paneleiro	1277x329x15
53	3/3	03	Porta Puerta Door	628x396x15
54	3/3	01	Porta menor Puerta más pequeña Smaller door	590x316x15
55	3/3	03	Porta aéreo Puerta modulo alto wall cabinet door	590x396x15
56	3/3	02	Porta superior torre Puerta superior de la torre Tower top door	590x293x15
57	3/3	02	Frente de gaveta Frente de cajón Drawer front	590x152x15
58	2/3	04	Lado de gaveta Lateral de cajón Drawer lateral	350x90x12
59	3/3	02	Fundo de gaveta Fondo de cajón Drawer bottom	542x361x3
60	2/3	02	Ripa de trás Pieza trasera de cajón Drawer back frame	555x90x12



Ind. e Com. de Móveis Henn
Mondai - SC - Brasil

+55 49 3674.3500

@moveishenn
www.henn.com.br

INSTRUÇÕES DE MONTAGEM

INSTRUCCIONES DE MONTAJE
ASSEMBLY INSTRUCTIONS

KIT COZINHA COMPACTA | KIT COCINA COMPACTA | COMPACT KITCHEN KIT

□ B126-127 NATURE/OFF WHITE

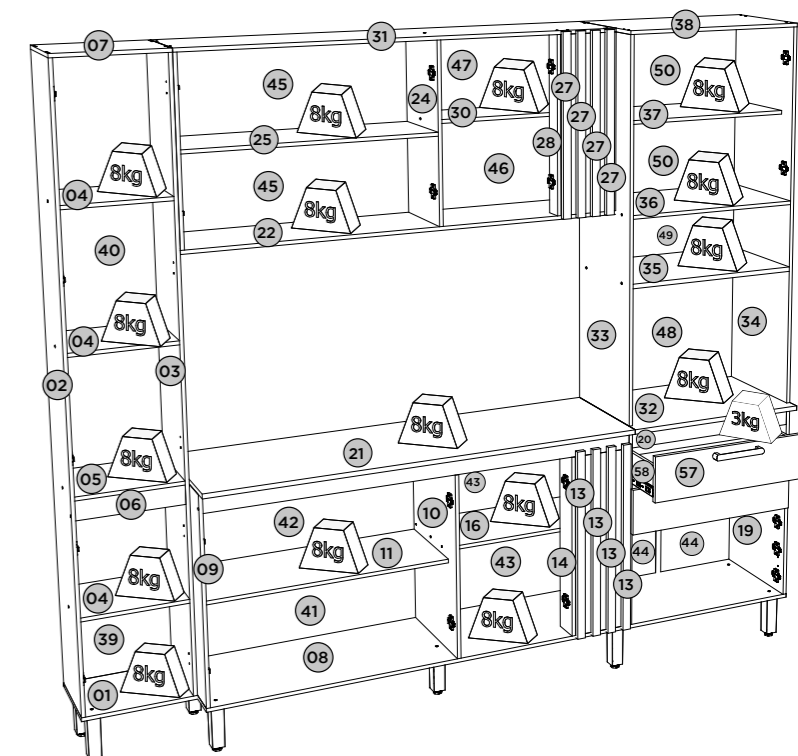

FERRAGENS | HERRAJES | HARDWARE

A 09x Parafuso 7,0x40mm CHT. Tornillo 7,0x40mm CHT. Screw 7,0x40mm CHT.	B 04x Parafuso 5,0x50mm FLA. Tornillo 5,0x50mm FLA. Screw 5,0x50mm FLA.	C 85x Parafuso 3,5x40mm CHT. Tornillo 3,5x40mm CHT. Screw 3,5x40mm CHT.	D 40x Parafuso 3,5x22mm CHT. Tornillo 3,5x22mm CHT. Screw 3,5x22mm CHT.	E 26x Parafuso 3,5x22mm CHT. Tornillo 3,5x22mm CHT. Screw 3,5x22mm CHT.
F 04x Parafuso 3,0x16mm CHT. Tornillo 3,0x16mm CHT. Screw 3,0x16mm CHT.	G 190x Parafuso 3,5x12mm CHT. Tornillo 3,5x12mm CHT. Screw 3,5x12mm CHT.	H 04x Prego 12x12mm Clavo 12x12mm Nail 12x12mm	I 02x Cavilha 5x60mm Cinta 5x60mm Dowel 5x60mm	J 114x Cavilha 5x25mm Cinta 5x25mm Dowel 5x25mm
K 256x Prego 10x10mm Clavo 10x10mm Nail 10x10mm	L 47x Fixador de fundos Fijador de fondos Bottom fixer	M 02x Suporte de Metal. Soporte Metálico. Metal Support.	N 23x Cantoneira plástica Cantonera plástica Plastic angle brackets	O 04x Cantoneira suporte triangular Cantonera soporte triangular Triangle support angle
P 04x Suporte de fixação Soporte de fijación Mounting bracket	Q 04x Bucha plástica 8mm Bucha de plástico 8mm 8mm plastic bushing	R 04x Proteção para cantoneira Ángulo de protección Protection angle	S 24x Dobradiça metal 26mm Alta Bisagra de metal de 26 mm de alto 26mm High Metal Hinge	T 24x Calço metal 5mm Calzado metálico 5mm 5mm metal shim
U 13x Puxador Ridanna 160mm Mango Ridanna 160mm Ridanna handle 160mm	V 09x Pé 145mm x 42mm Pie 145mm x 42mm Foot 145mm x 42mm	W 02x PAR Corrediça telescópica Diapositivas telescópicas Telescopic slides	X 01x Perfil "I" 672mm Perfil "I" 672mm Profile "I" 672mm	Y 78x Adesivo tapa parafuso 10mm Adhesivo tapón de tornillo 10mm Bolt cover adhesive 10mm
Z 10x Adesivo tapa parafuso 17mm Adhesivo tapón de tornillo 17mm Bolt cover adhesive 17mm	AA 01x Sachê de cola Bolsa de pegamento Glue bag	AB 01x Etiqueta resinada Briz Etiqueta resinada Briz Briz resin label		

Requisitos para montagem
Requisitos para la montaje
Assembly Requirements

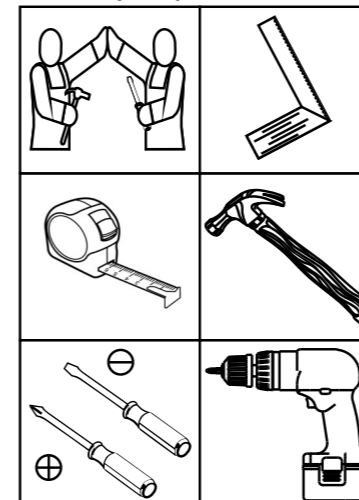

Imagens meramente ilustrativas,
não acompanha o produto.
Imágenes ilustrativas, no incluidas
con el producto.
Illustrative images, not included
with the product.

Pesos máximos recomendados com carga distribuída
Peso máximo recomendado con la carga distribuída
Recommended maximum weights with evenly distributed.

AVISO
Para limpeza de seu móvel, use uma flanela seca ou umedecida, e não utilize produtos químicos que possam danificar seu produto.

SISTEMA DE MONTAGEM
O sistema de montagem dos produtos, funciona de acordo com a ordem crescente dos números indicados no desenho. Ex: 01, 02, 03, 04... até a conclusão da montagem.

ASSISTÊNCIA TÉCNICA
Para solicitação de Assistência Técnica você consumidor deverá entrar em contato com o Lojista ou qual você realizou a compra deste produto e solicitar a assistência técnica para as partes avariadas. A garantia abrange todas as peças, partes e componentes que eventualmente venham apresentar defeito de fabricação no prazo de 03 (três) meses, contando a partir da entrega do produto ao consumidor, mediante nota fiscal de compra. Se houver qualquer alteração na estrutura do produto ou ocorrer defeito por negligência do montador/consumidor em relação a instrução de montagem e manuseio, não será fornecido assistência técnica gratuita.

ADVERTENCIA
Para limpieza de su móvil, use una flanela seca o húmeda, y no utilice productos químicos que puedan dañar su producto.

SISTEMA DE MONTAJE
El sistema de montaje de los productos funciona de acuerdo con el orden creciente de los números indicados en el dibujo. Ej.: 01, 02, 03, 04... hasta la conclusión del montaje.

ASISTENCIA TÉCNICA
Para solicitar Asistencia Técnica, el consumidor debe comunicarse con el Comercio que usted realizó la compra de este producto y solicita asistencia técnica para las partes dañadas. La garantía cubre todas las partes, piezas y componentes que eventualmente puedan presentar defecto de fabricación en el plazo de 03 (tres) meses, contados a partir de la entrega del producto al consumidor, mediante factura de compra. Si se produce algún cambio en la estructura del producto o se produce un defecto por negligencia del montador/consumidor en relación con las instrucciones de montaje y manipulación, no se prestará asistencia técnica gratuita.

NOTICE
To clean your furniture, use a dry or wet cloth, and do not use chemicals that may damage your product.

ASSEMBLY SYSTEM
The products' assembly system works according to the increasing order of the indicated numbers. For example: 01, 02, 03, 04 ... to the end of the assembly.

TECHNICAL ASSISTANCE
To request Technical Assistance, the consumer must contact the retailer from whom you purchased this product and request technical assistance for the damaged parts. The warranty covers all parts, parts and components that may eventually present a manufacturing defect within a period of 03 (three) months, counting from the delivery of the product to the consumer, by means of a purchase invoice. If there is any change in the structure of the product or defect occurs due to negligence of the assembler/consumer in relation to the assembly and handling instruction, free technical assistance will not be provided.

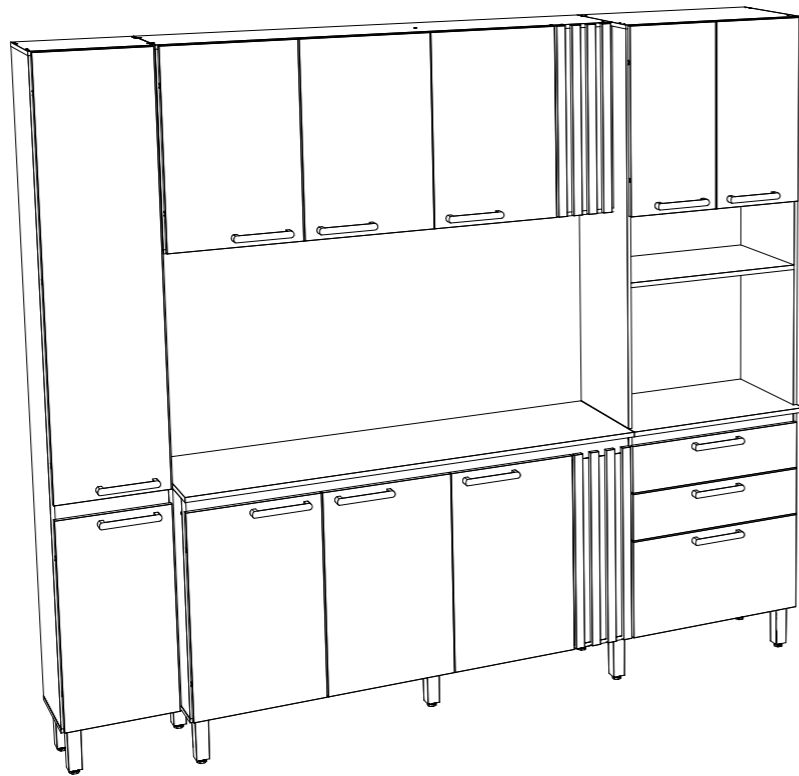

Montagens na opção 01
 Se monta en la opción 01
 Assemblies in option 01



Montagem da opção 02 a partir da página 11
 Opción de montaje 02 de la página 11
 Mounting option 02 starting on page 11

Item	Caixa Caja Box	Qty	Descrição Descripción Description	Medidas (mm) Dimensiones (mm) Size (measurements) (mm)
1	2/3	01	Base paneleiro Base paneleiro Paneleiro base	344x265x12
2	2/3	01	Lateral esquerda paneleiro Paneleiro lado izquierdo Paneleiro left side	1931x265x12
3	2/3	01	Lateral direita paneleiro Paneleiro lado derecho Paneleiro right side	1931x265x12
4	2/3	03	Prateleira paneleiro Estante paneleiro Shelf paneleiro	319x265x12
5	2/3	01	Prateleira maior paneleiro Estante más grande Paneleiro Paneleiro Larger Shelf	319x265x12
6	2/3	01	Travessa frontal paneleiro Travesaño frontal despensero Pantry frontal frame	319x60x12
7	2/3	01	Tampo paneleiro Tapa para Despensero Pantry top	344x265x12
8	1/3	01	Base balcão Base balcão Balcony base	2005x365x12
9	1/3	01	Lateral esquerda inferior Lado inferior izquierdo Lower Left Side	660x365x12
10	1/3	01	Divisão balcão División balcão Balcony division	600x365x12
11	1/3	01	Prateleira maior Estante más grande Larger Shelf	786x300x12
12	2/3	01	Frente fixa Frente fijo Fixed Front	600x192x12
13	3/3	04	Aplique Aplicarse Apply	628x28x15
14	2/3	01	Pilastra da porta Pilastra de puerta Door pillar	600x90x12
15	1/3	01	Lateral direita inferior Lateral inferior derecho Lower right side	660x365x12
16	2/3	01	Prateleira balcão Estante de mostrador Counter Shelf	590x275x12
17	2/3	01	Travessa frontal maior Travesaño frontal más grande Larger front cross member	1388x60x12
18	2/3	01	Travessa traseira maior Travesaño trasero más grande Larger rear crossmember	1388x60x12
19	1/3	01	Lateral direita esquerda Lado derecho izquierdo Right side left	660x365x12
20	2/3	01	Travessa frontal Travesaño frontal Frontal frame	580x60x12
21	1/3	01	Tampo 1400mm Tapa 1400mm 1400mm top	1400x408x15
22	2/3	01	Base aéreo Base aereo Air base	1401x265x12
23	2/3	01	Lateral esquerda aéreo Lado izquierdo aéreo Aerial Left Side	570x265x12
24	2/3	01	Divisão aéreo División aéreo Air division	570x265x12
25	2/3	01	Prateleira aéreo Estante aereo Air shelf	786x265x12
26	2/3	01	Frente fixa superior Frente fijo superior Superior Fixed Front	570x180x12
27	3/3	04	Aplique menor Aplicars más pequeño Smaller apply	590x28x15
28	2/3	01	Pilastra aéreo pilastra aereo Air Pillar	570x60x12
29	2/3	01	Lateral direita aéreo Lateral derecho aéreo Aerial Right Back	570x265x12
30	2/3	01	Prateleira Estante Shelf	578x205x12
31	2/3	01	Tampo aéreo Tapa Modulo Alto Wall cabinet top	1401x265x12
32	1/3	01	Tampo Torre Quente Cima de la torre caliente Hot Tower Top	605x408x15
33	1/3	01	Lateral esquerda torre quente Lateral Izquierda Despensero Pantry left lateral	1256x365x12
34	3/3	01	Lateral direita torre quente Lateral Derecha Despensero Pantry right lateral	1256x365x12
35	1/3	01	Prateleira Central Estante Central Central Shelf	580x365x12
36	1/3	01	Base Aéreo Torre Base aérea de la torre Tower Air Base	586x365x15
37	1/3	01	Prateleira superior torre Estante superior de la torre Tower top shelf	580x300x12
38	1/3	03	Tampo Superior Tapa superior Upper top	605x365x12
39	3/3	01	Fundo menor paneleiro Fondo menor despensero Pantry minor back	678x340x3
40	3/3	01	Fundo maior paneleiro Fondo mayor despensero Pantry major back	1277x340x3
41	3/3	01	Fundo menor Balcão Fondo balcão Menor Minor Balcony Fund	802x310x3
42	3/3	01	Fundo maior balcão Fondo mayor balcão Biggest balcony fund	802x366x3
43	3/3	02	Fundo menor inferior Fondo menor inferior Lower minor fund	601x337x3
44	3/3	02	Fundo inferior torre quente Fondo inferior torre caliente Hot tower bottom background	678x298x3
45	3/3	02	Fundo maior aéreo Fondo de aire mayor Greater air fund	802x295x3
46	3/3	01	Fundo Aéreo Fondo Aéreo Air Fund	594x324x3
47	3/3	01	Fundo Menor Aéreo Fondo menor aéreo Aerial Minor Fund	594x266x3
48	3/3	02	Fundo maior torre Fondo de la torre más grande Biggest tower background	601x463x3
49	3/3	01	Fundo menor torre quente Fondo de torre caliente más pequeña Smaller hot tower background	601x222x3
50	3/3	01	Fundo superior torre quente Fondo superior de la torre caliente Top hot tower background	601x291x3

1

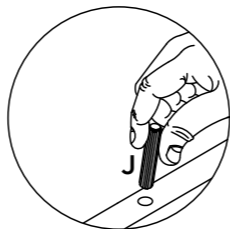
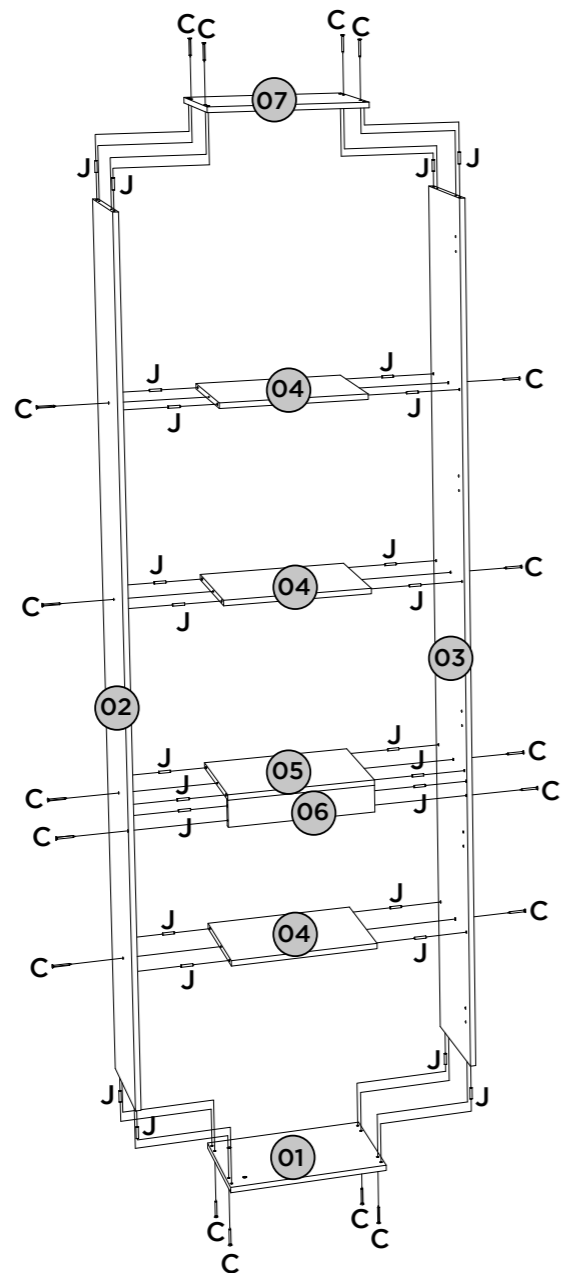
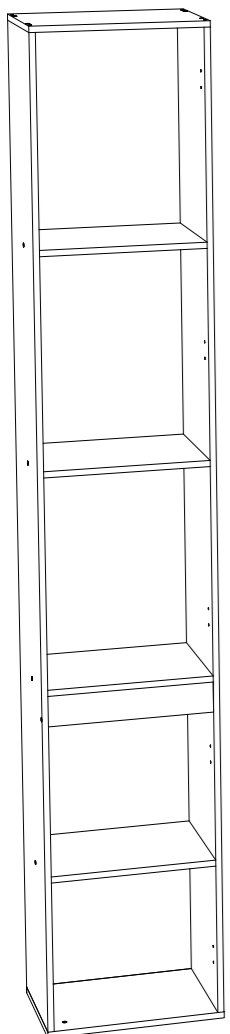

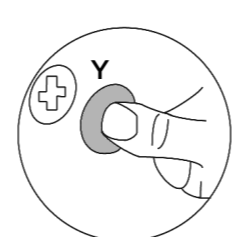
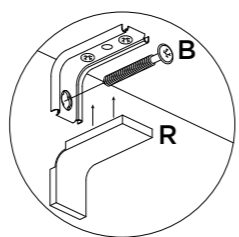
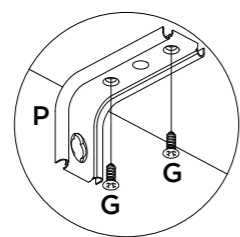
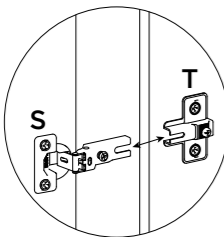
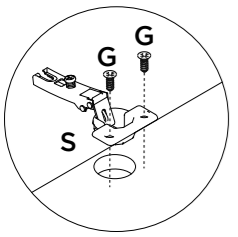
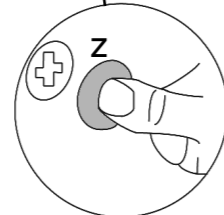
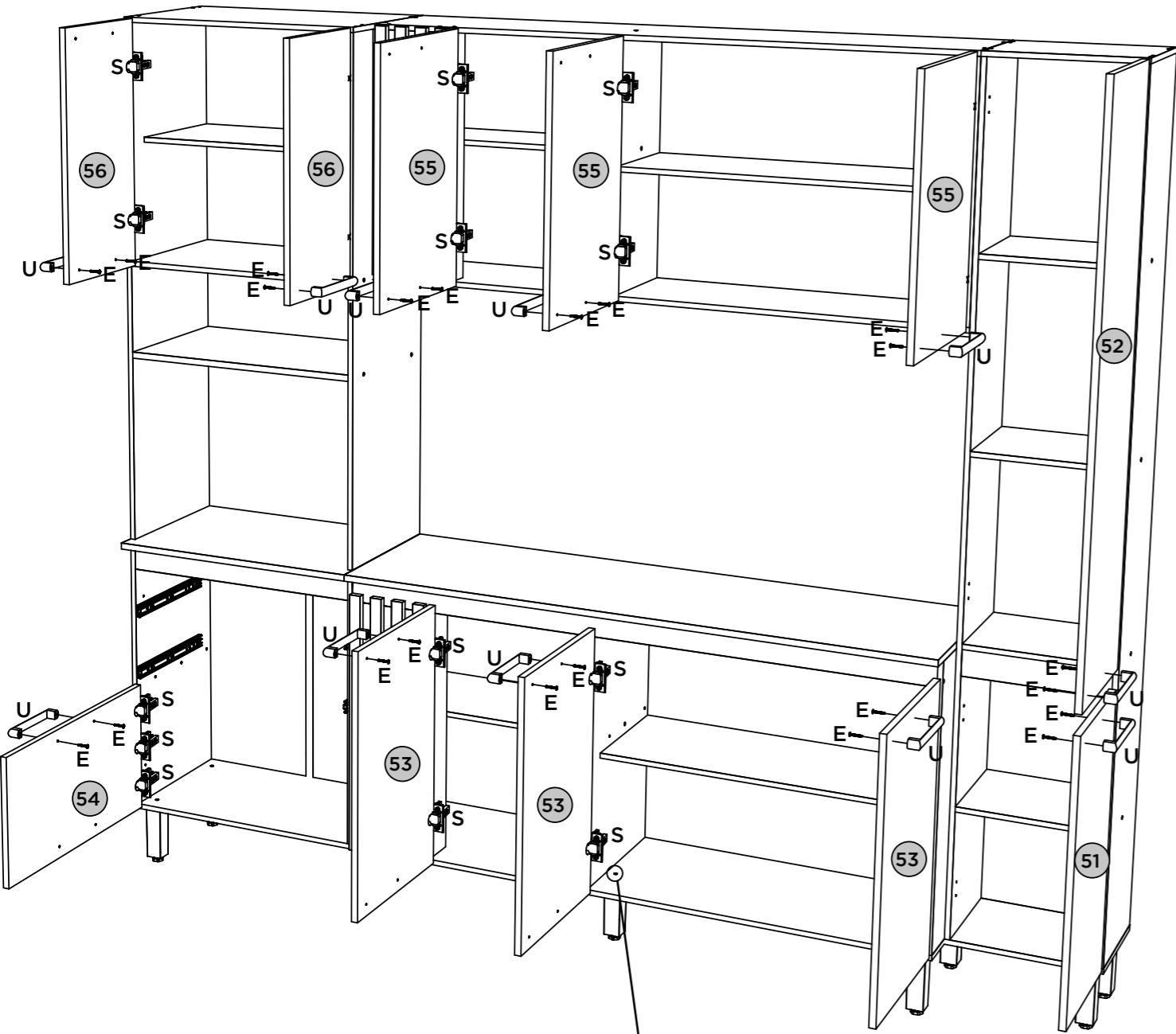

Video: Instalar e regular Dobradiças
 Video: Instale y ajuste las bisagras
 Video: Install and adjust hinges

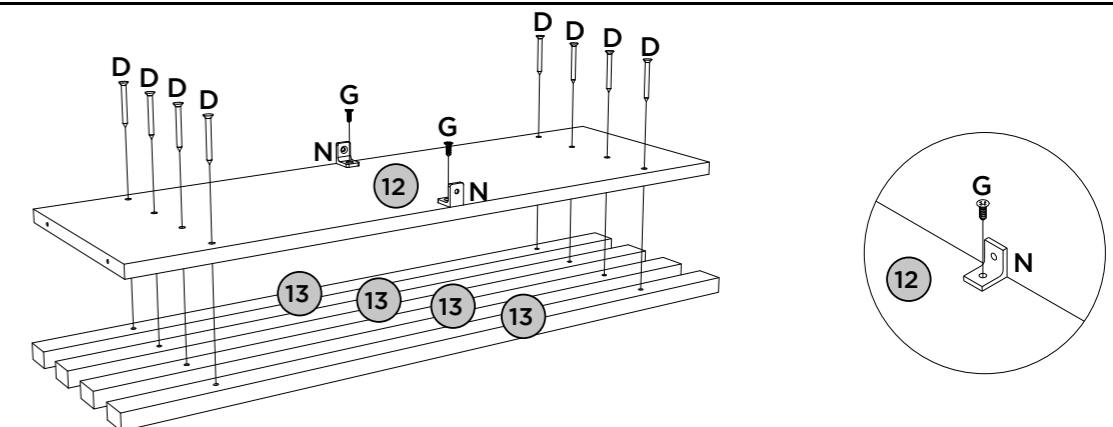
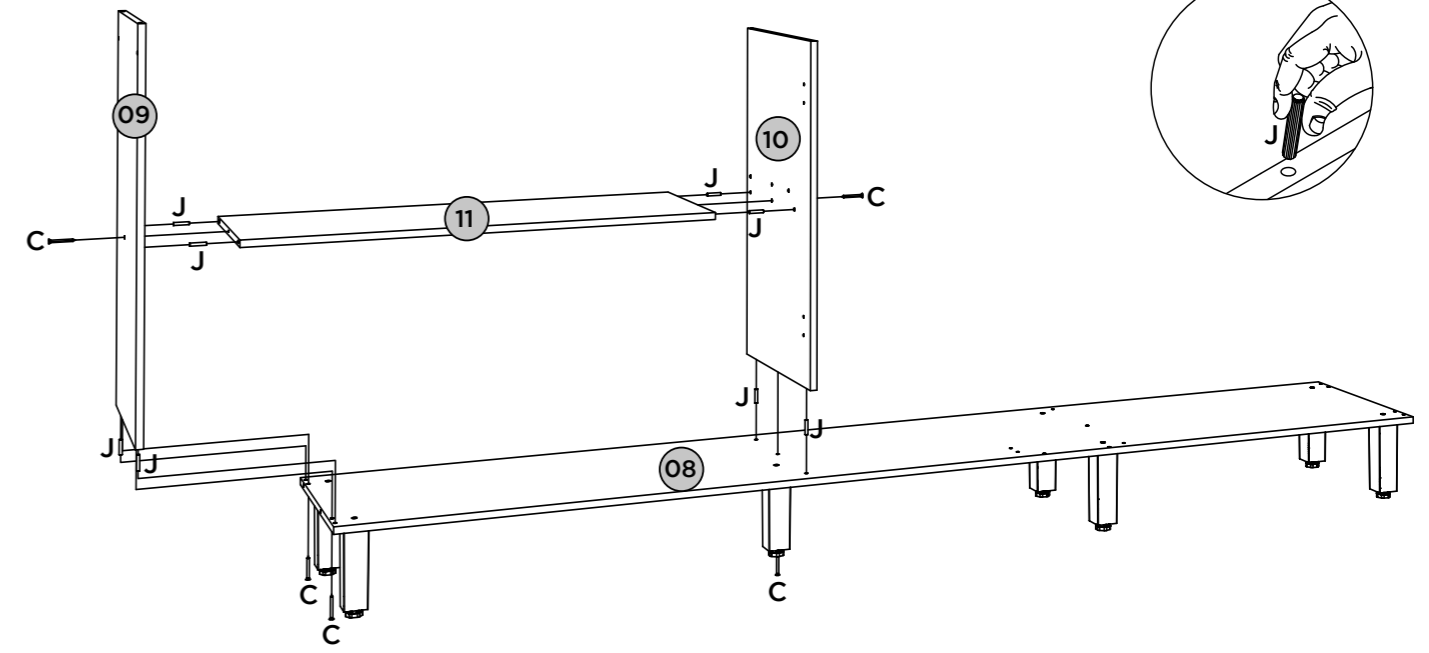
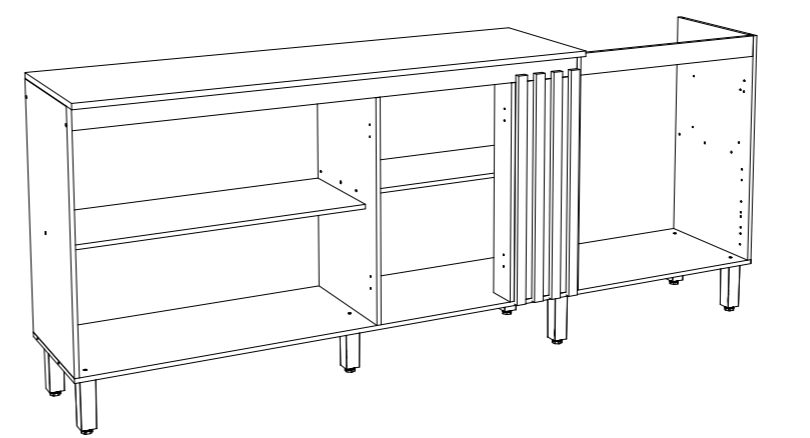
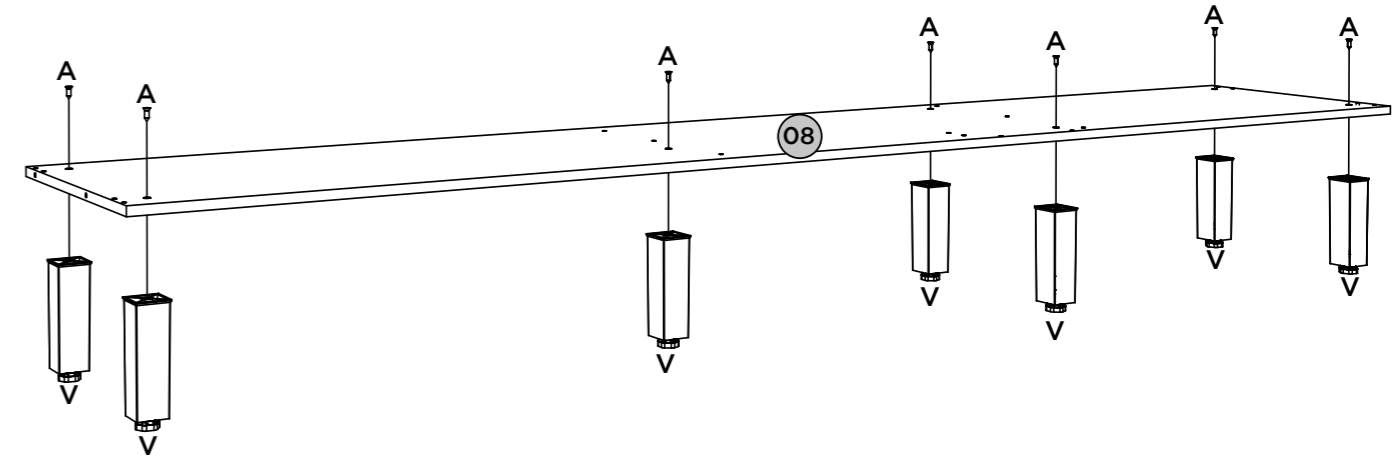

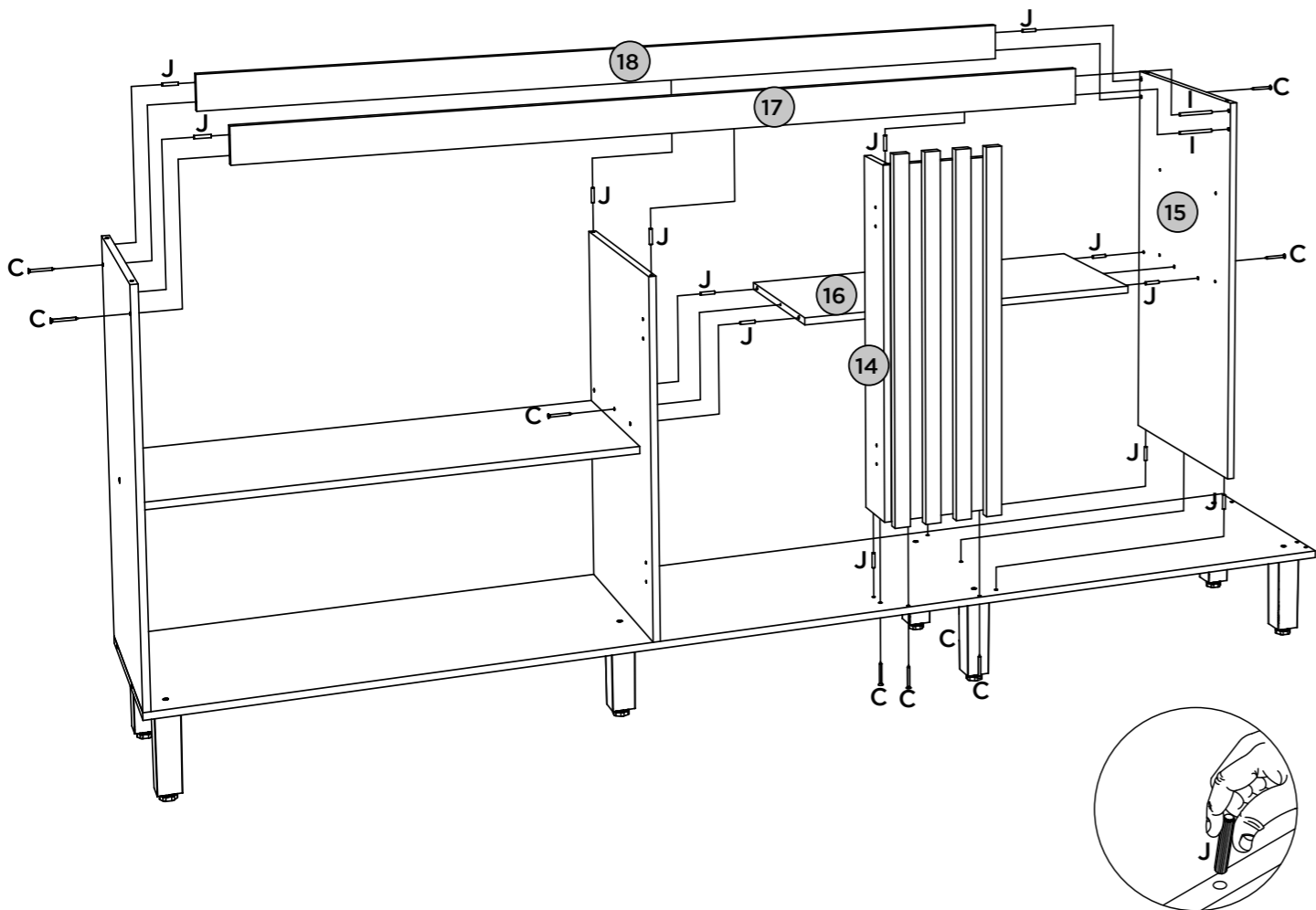

Vista Traseira
 Vista trasera
 Back view

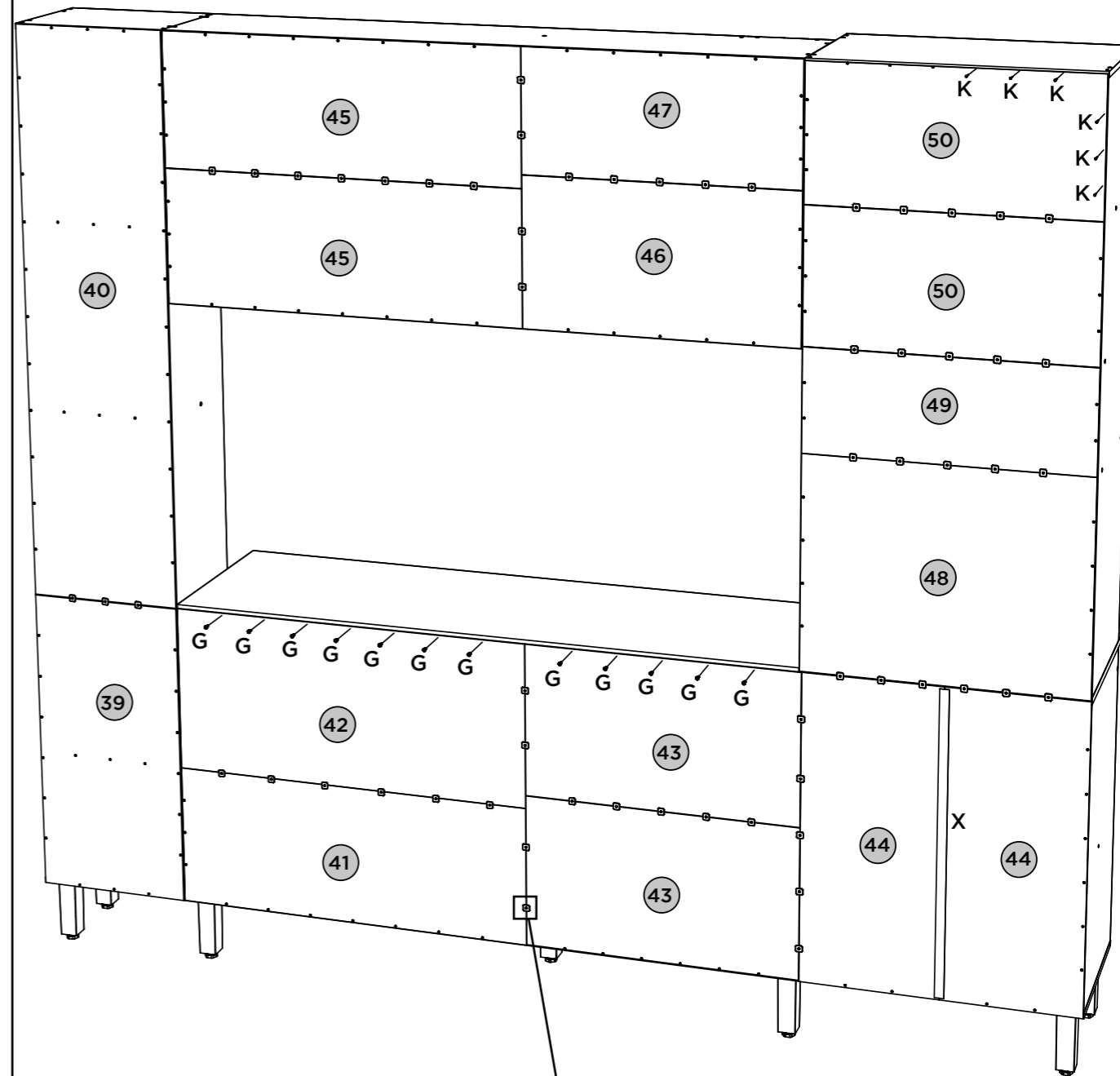
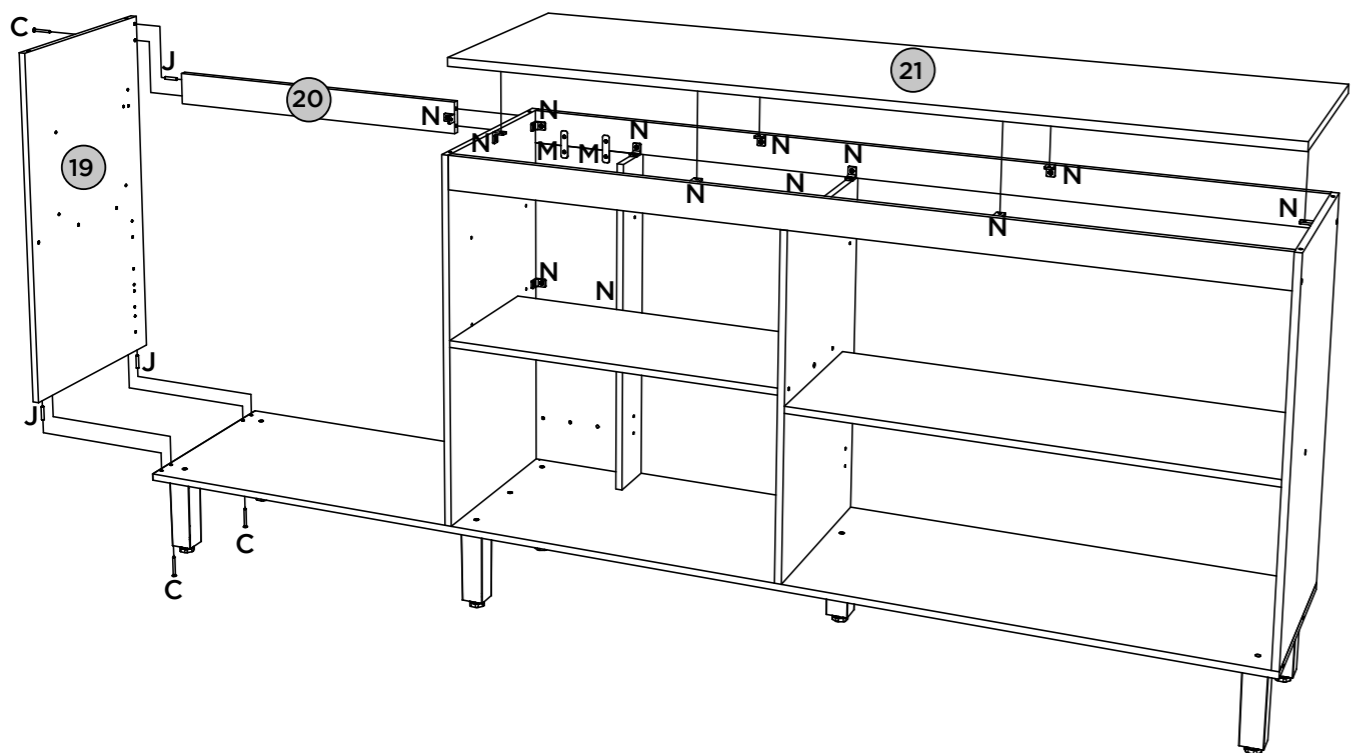
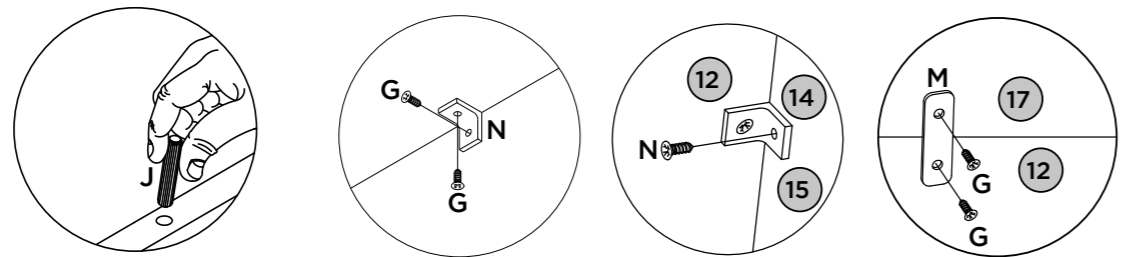

Fixar os pregos a uma distância de 120mm de um para outro.

Fijar las uñas a un distancia de 120 mm uno a otro.

Fix the nails at a distance of 120mm from one to the other

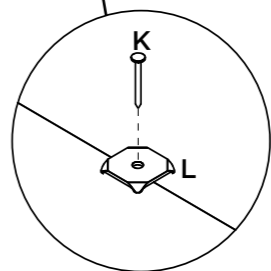

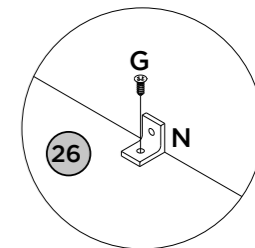
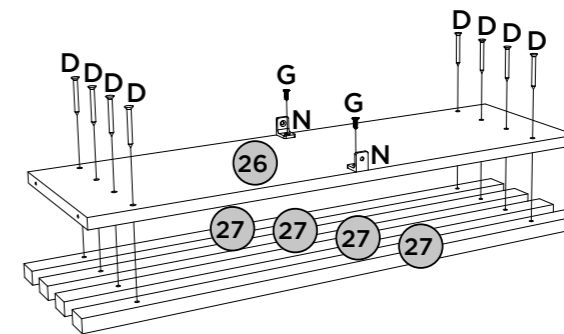
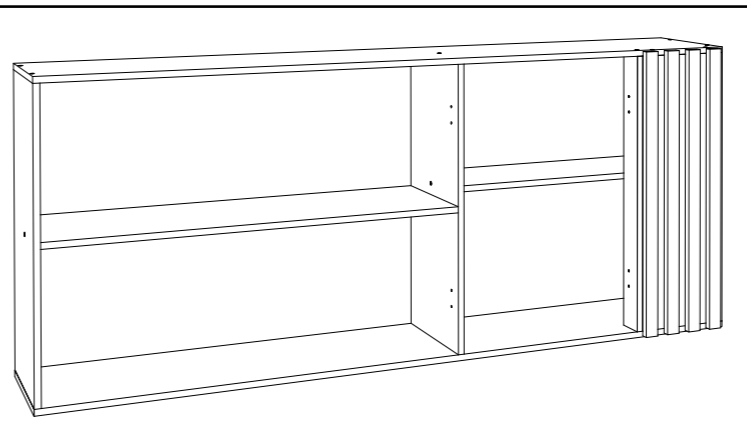
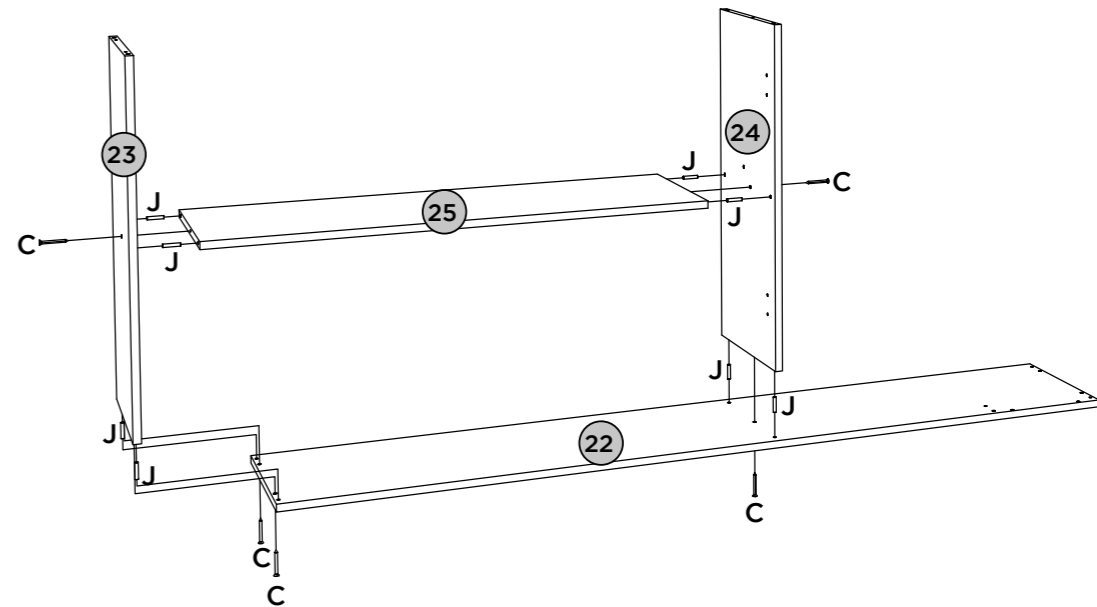
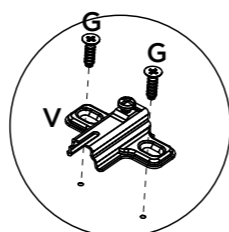
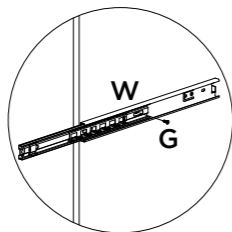
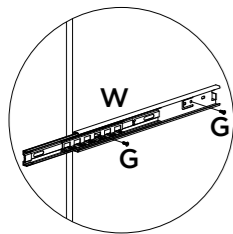
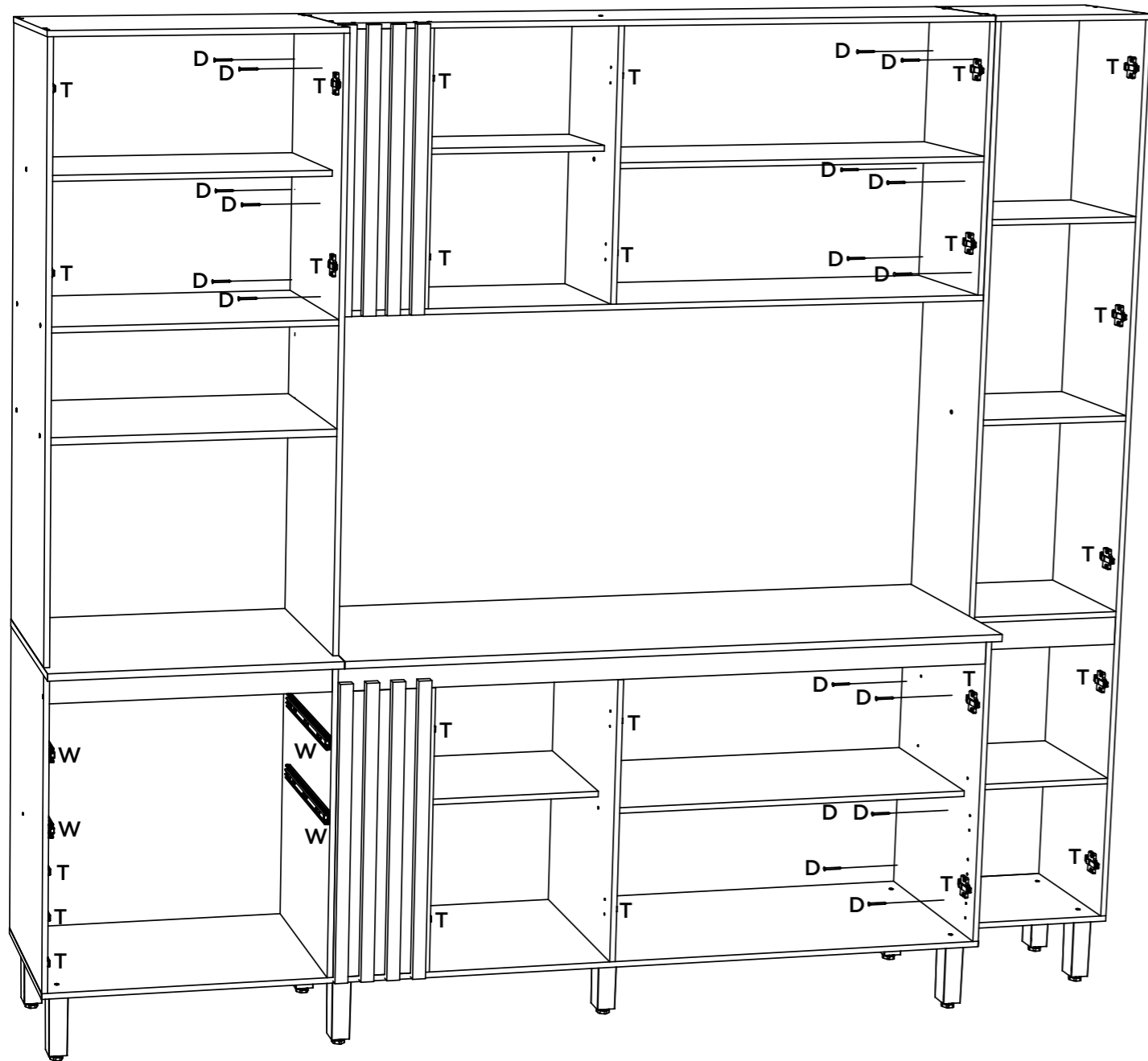

Vista Traseira
 Vista trasera
 Back view

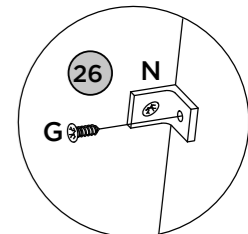
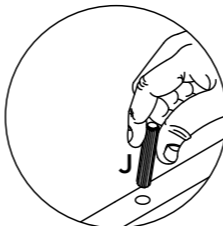
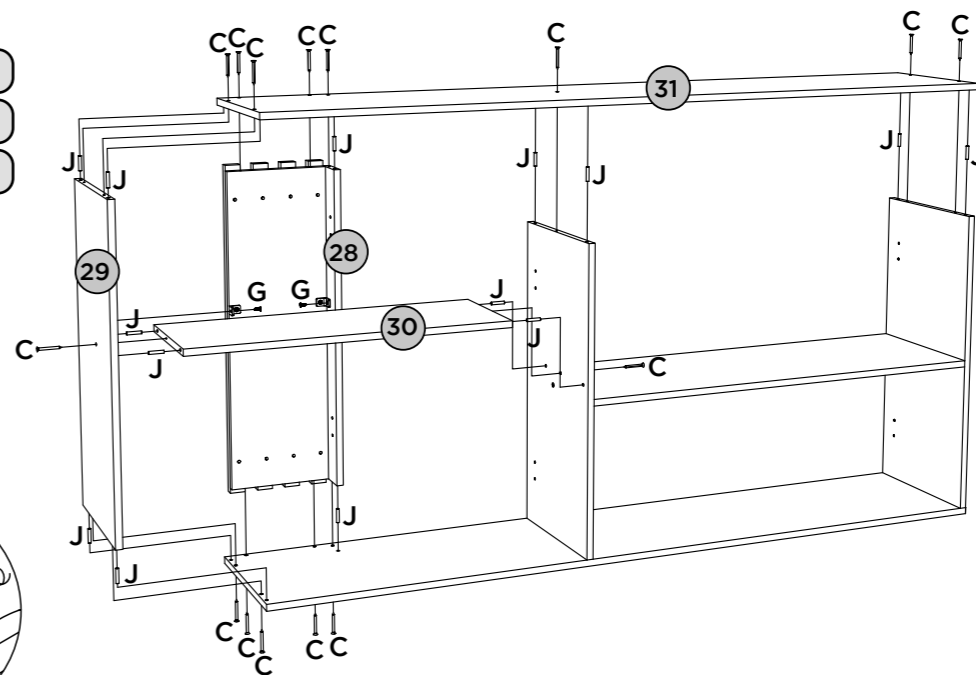

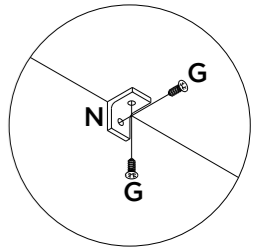
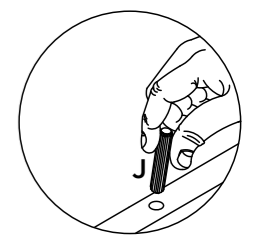
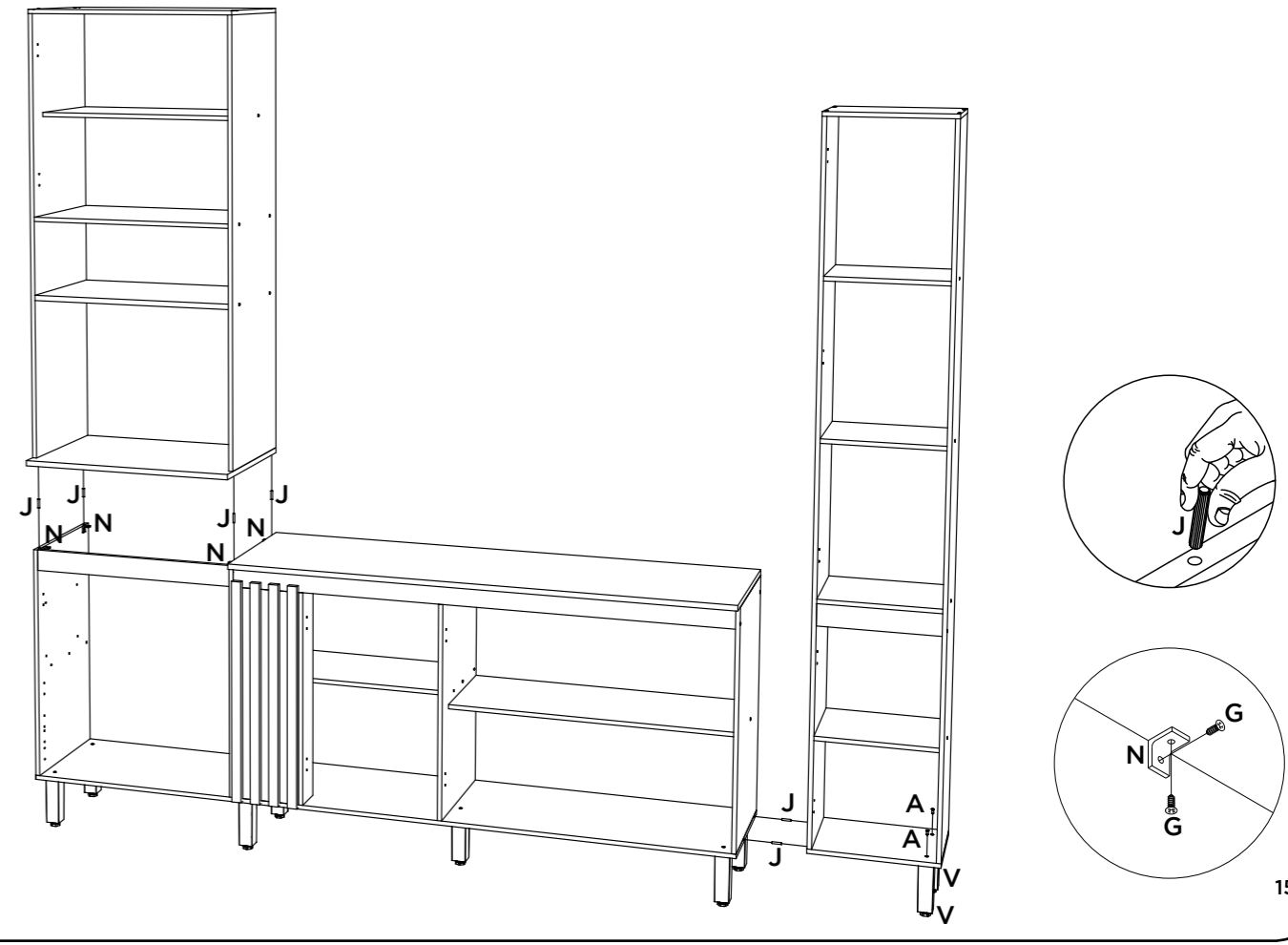
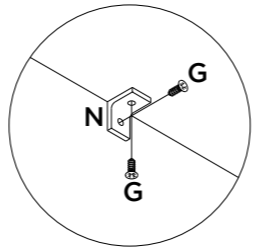
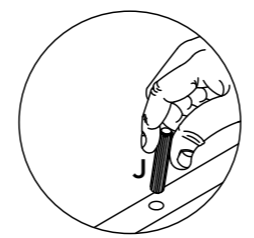
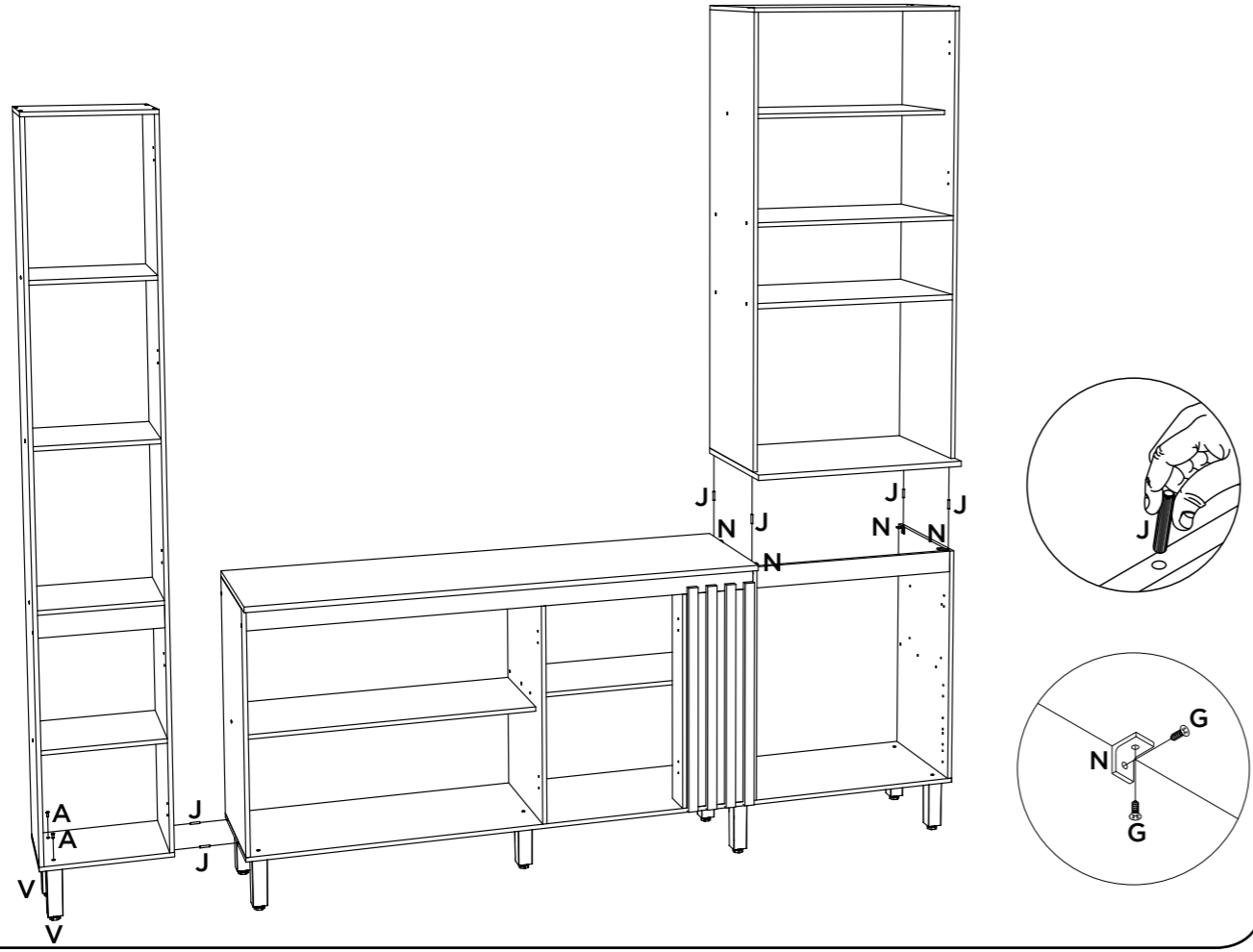
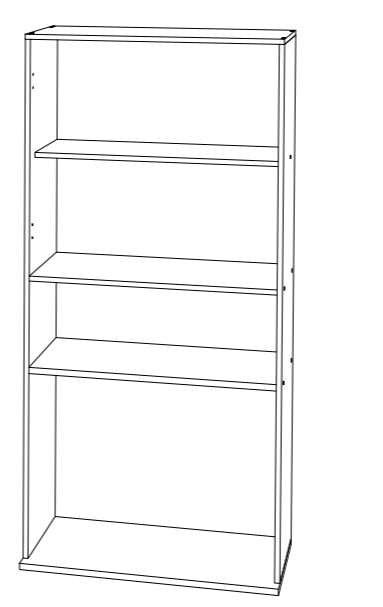
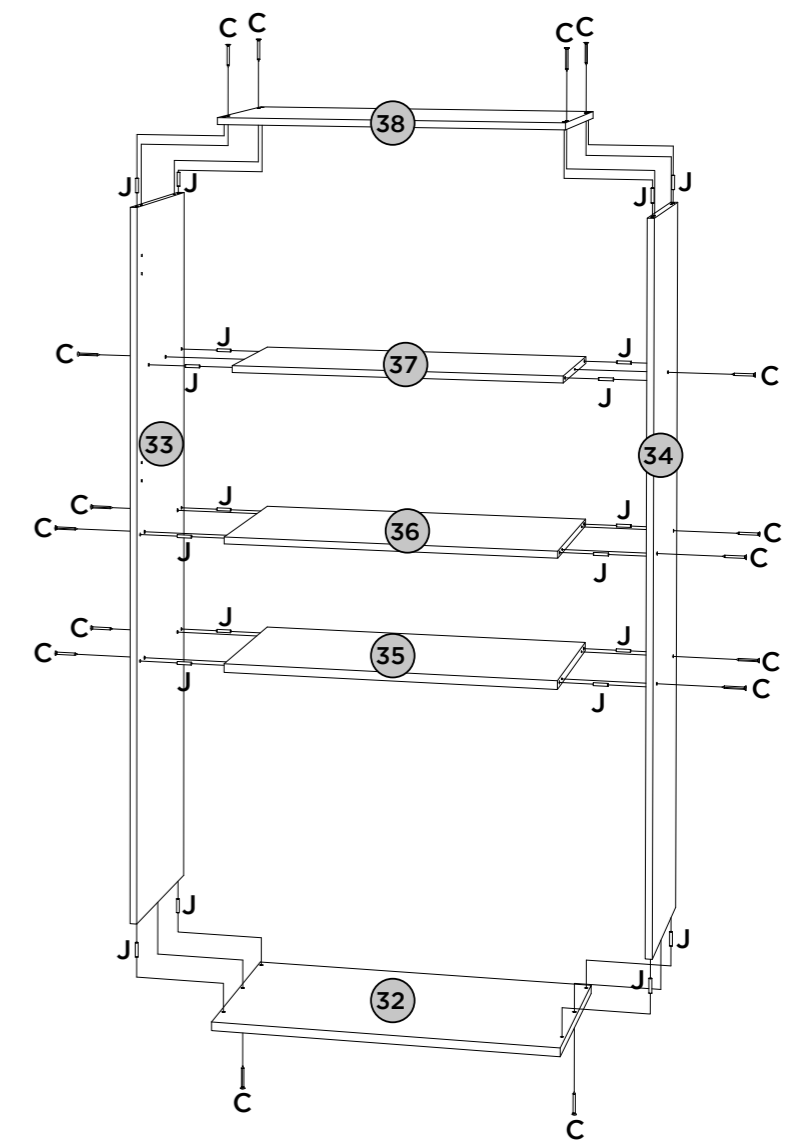
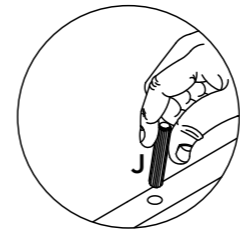
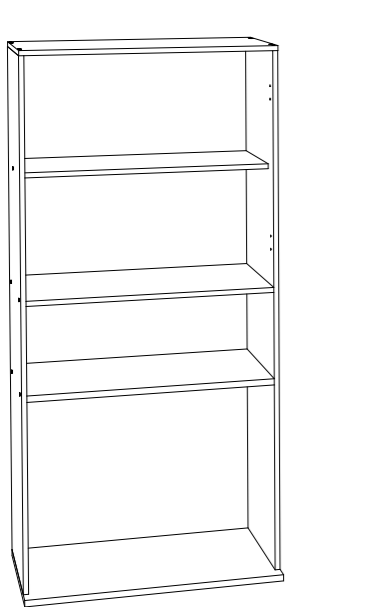
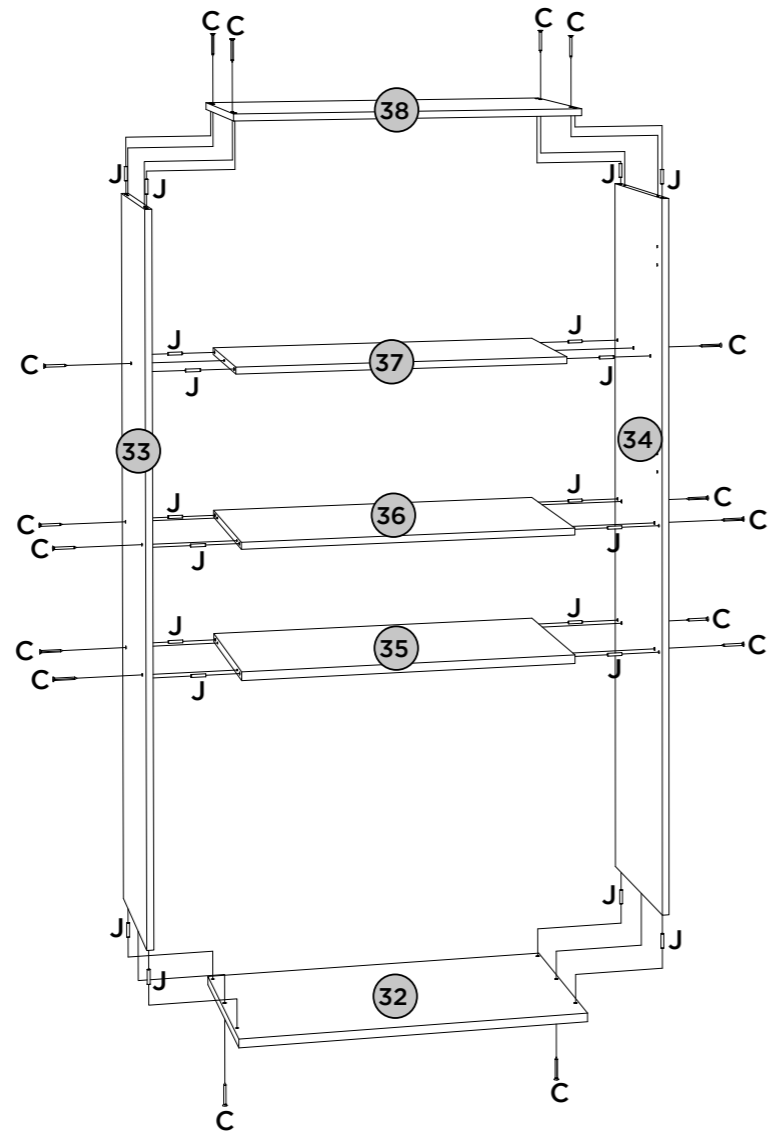
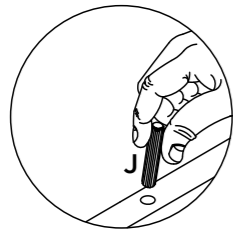

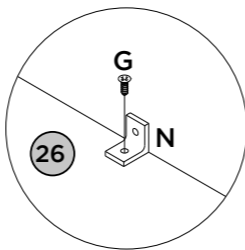
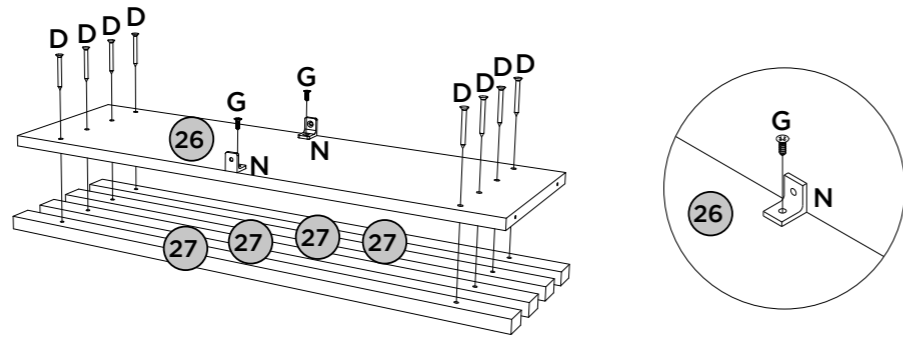
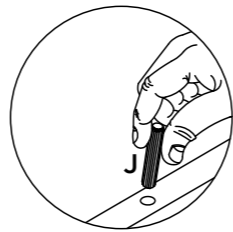
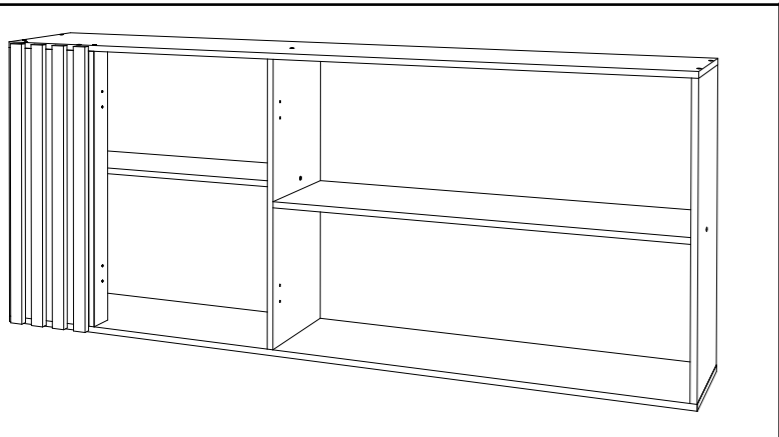
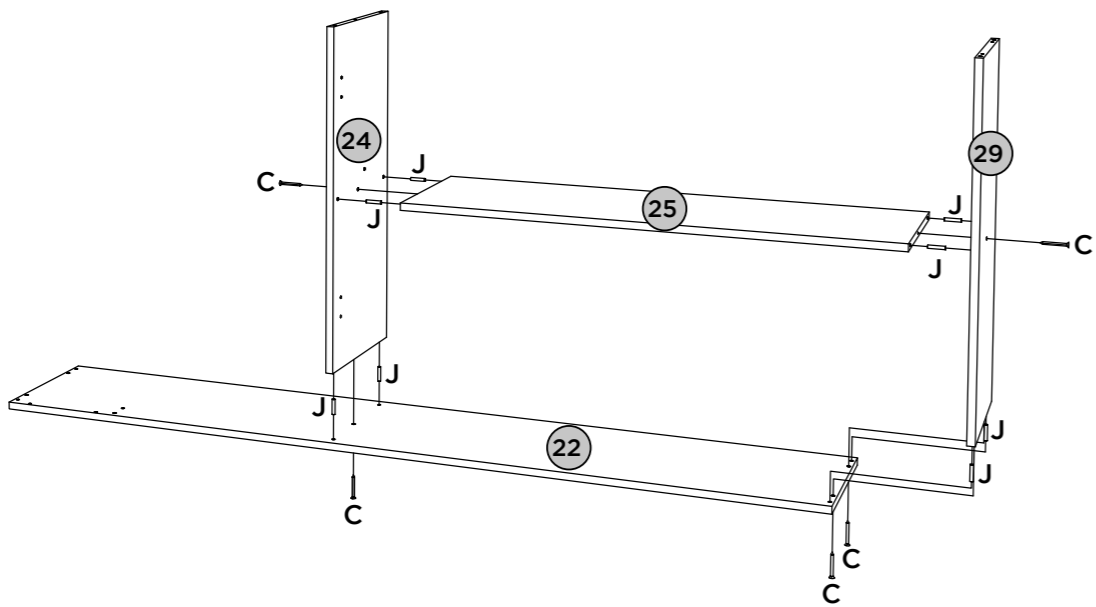

Vista Traseira
 Vista trasera
 Back view

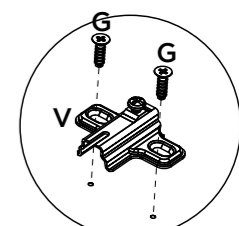
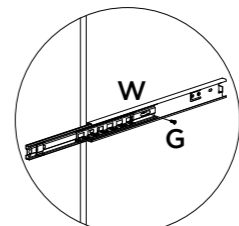
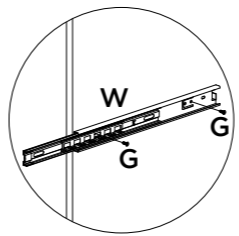
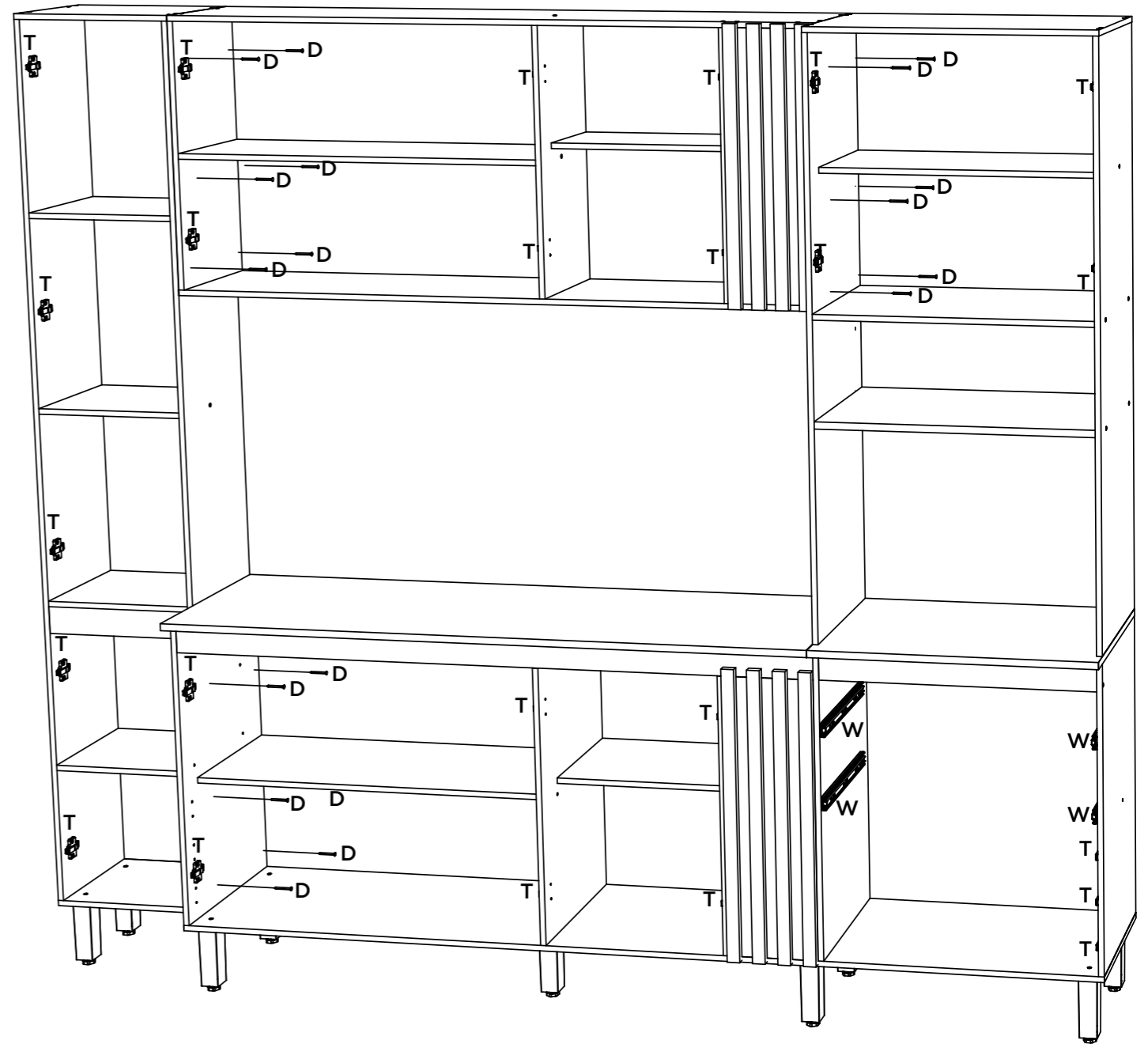
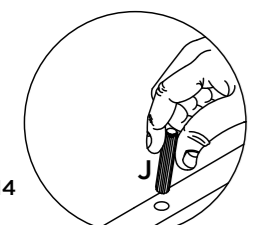
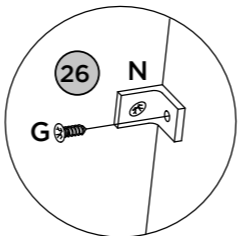
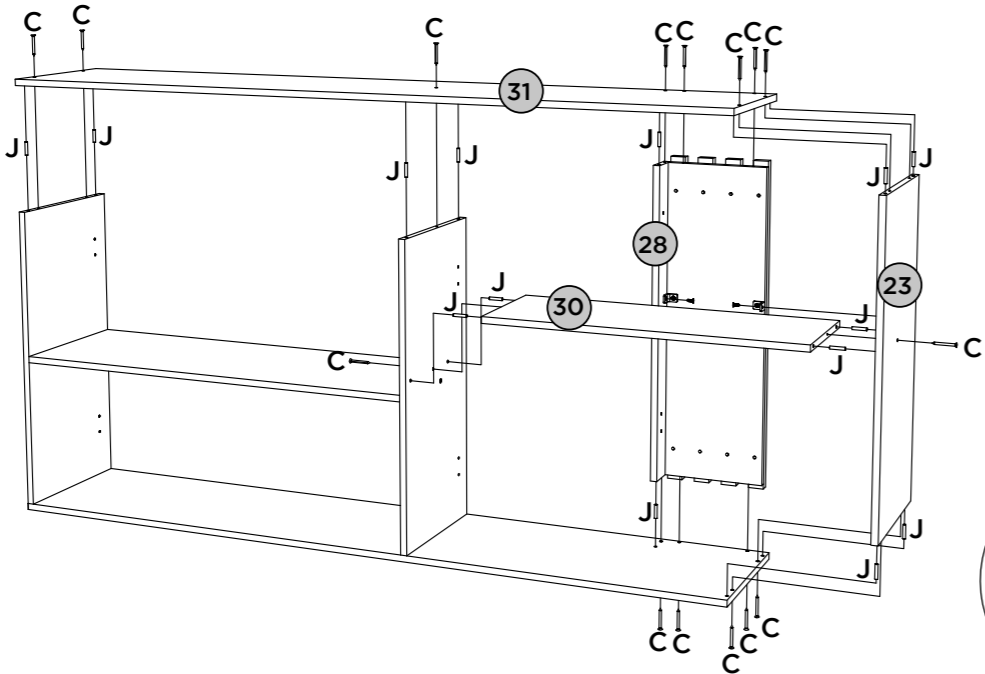

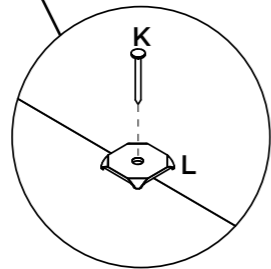
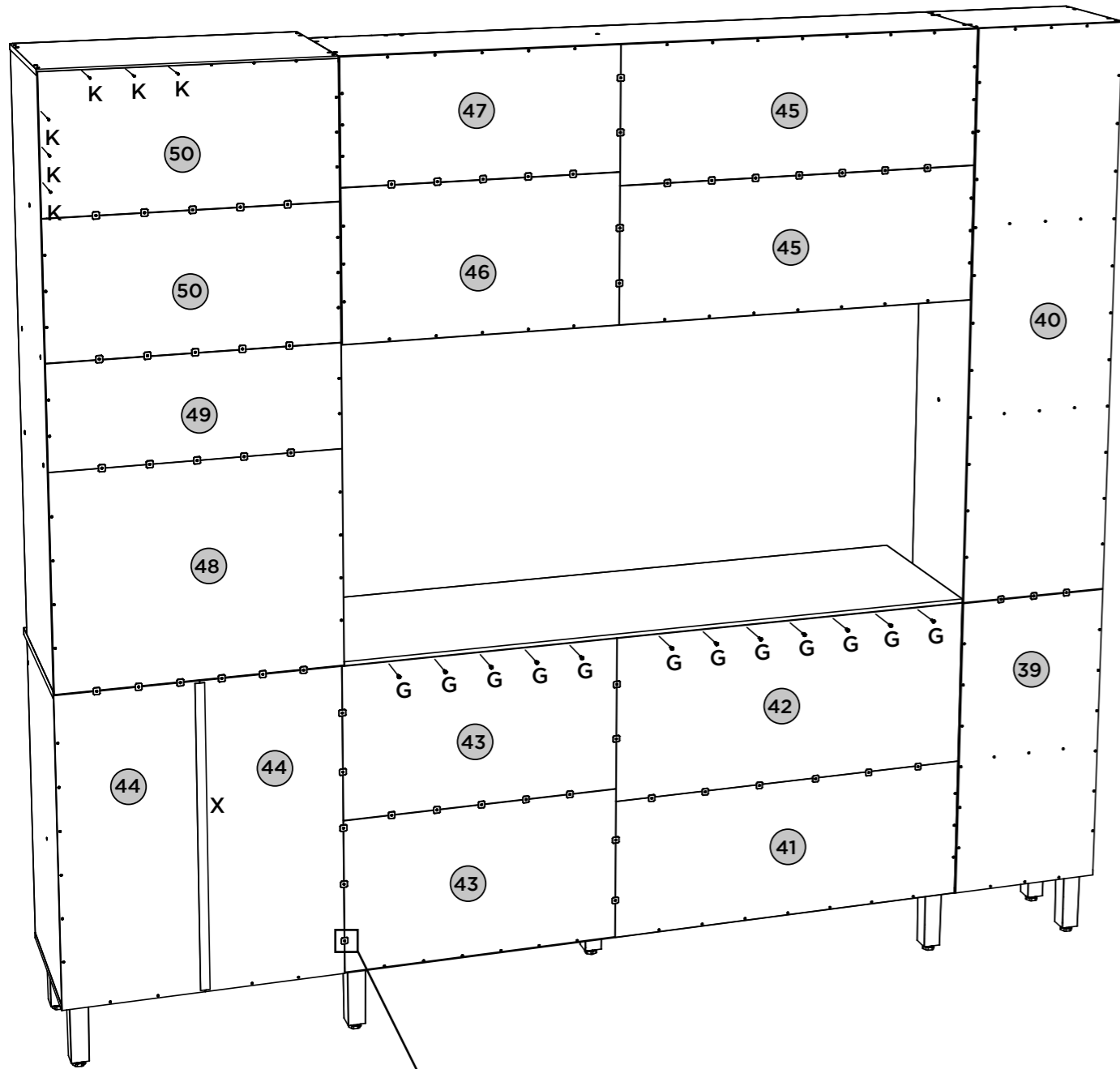

Fixar os pregos a uma distância de 120mm de um para outro.

Fijar las uñas a un distancia de 120 mm uno a otro.

Fix the nails at a distance of 120mm from one to the other

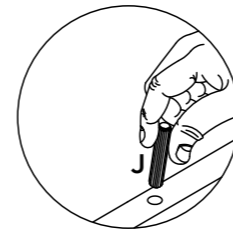
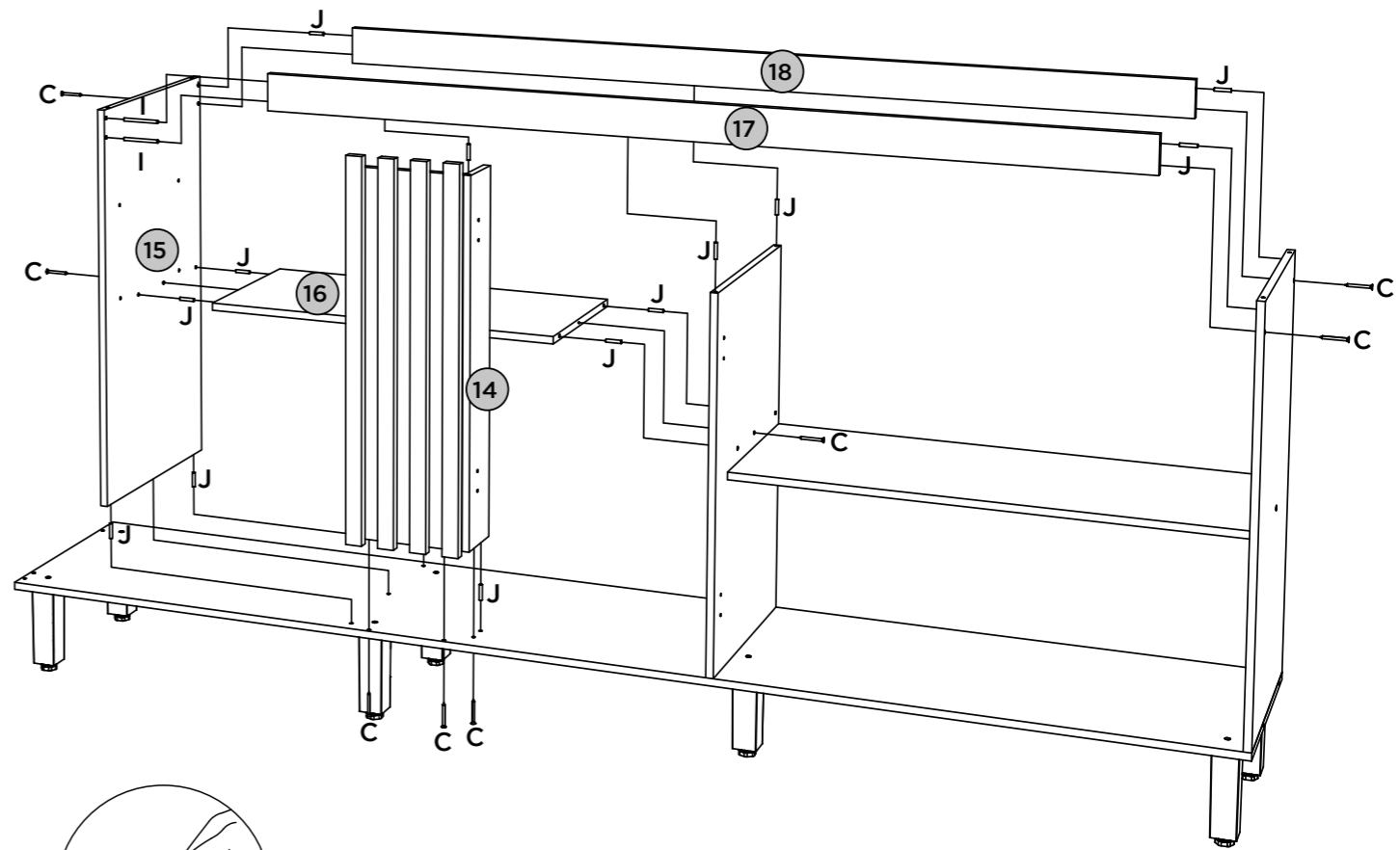

Vista Traseira
Vista trasera
Back view

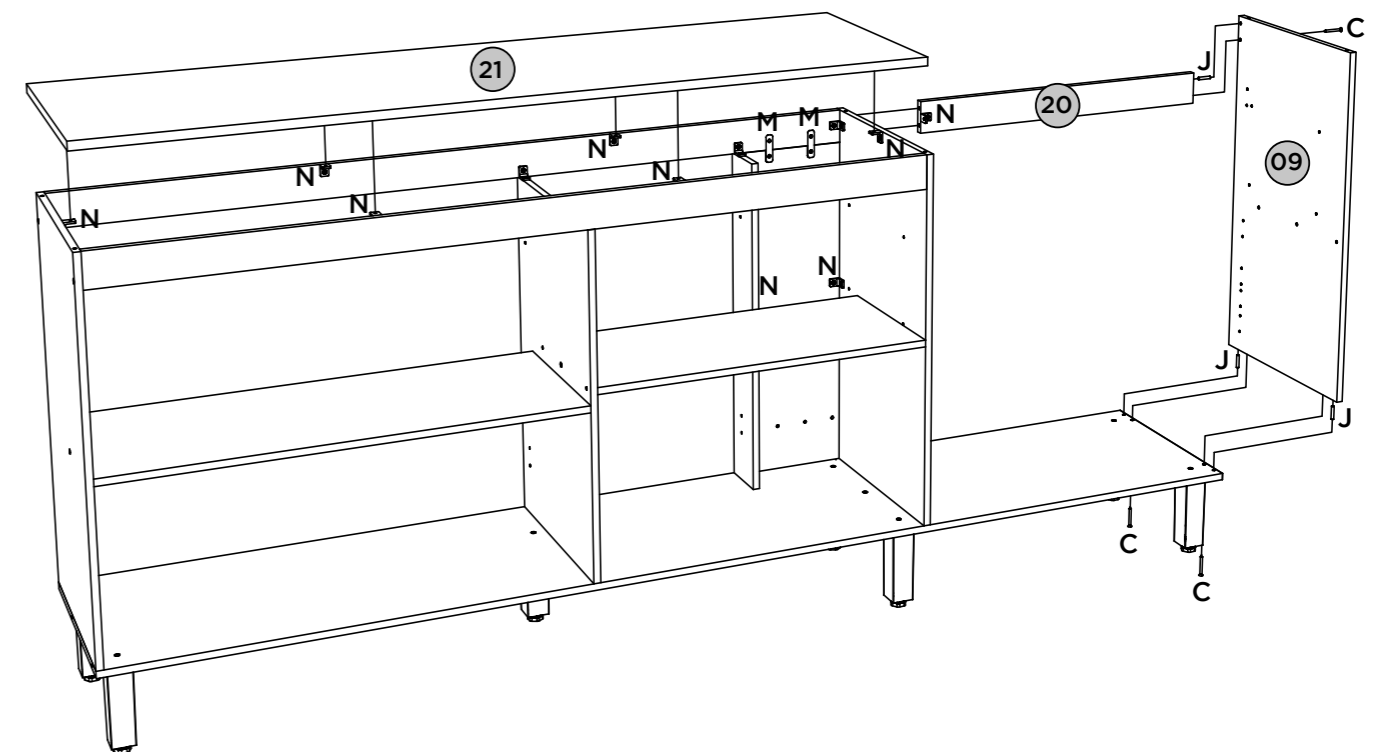
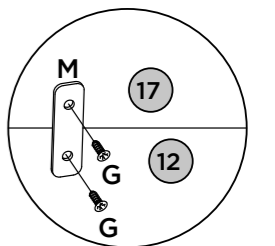
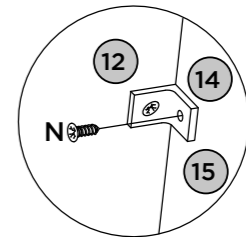
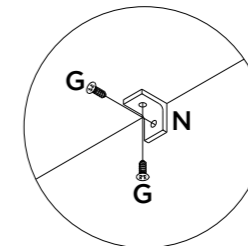
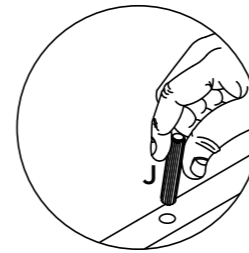

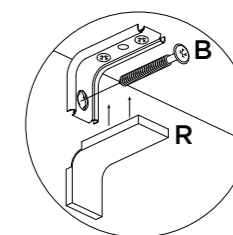
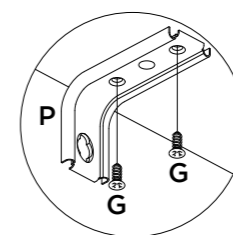
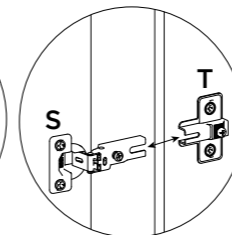
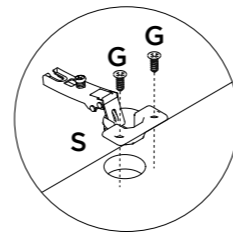
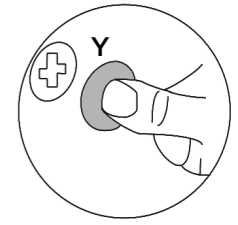
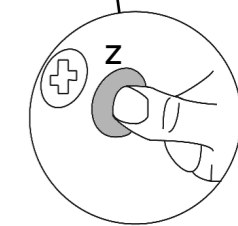
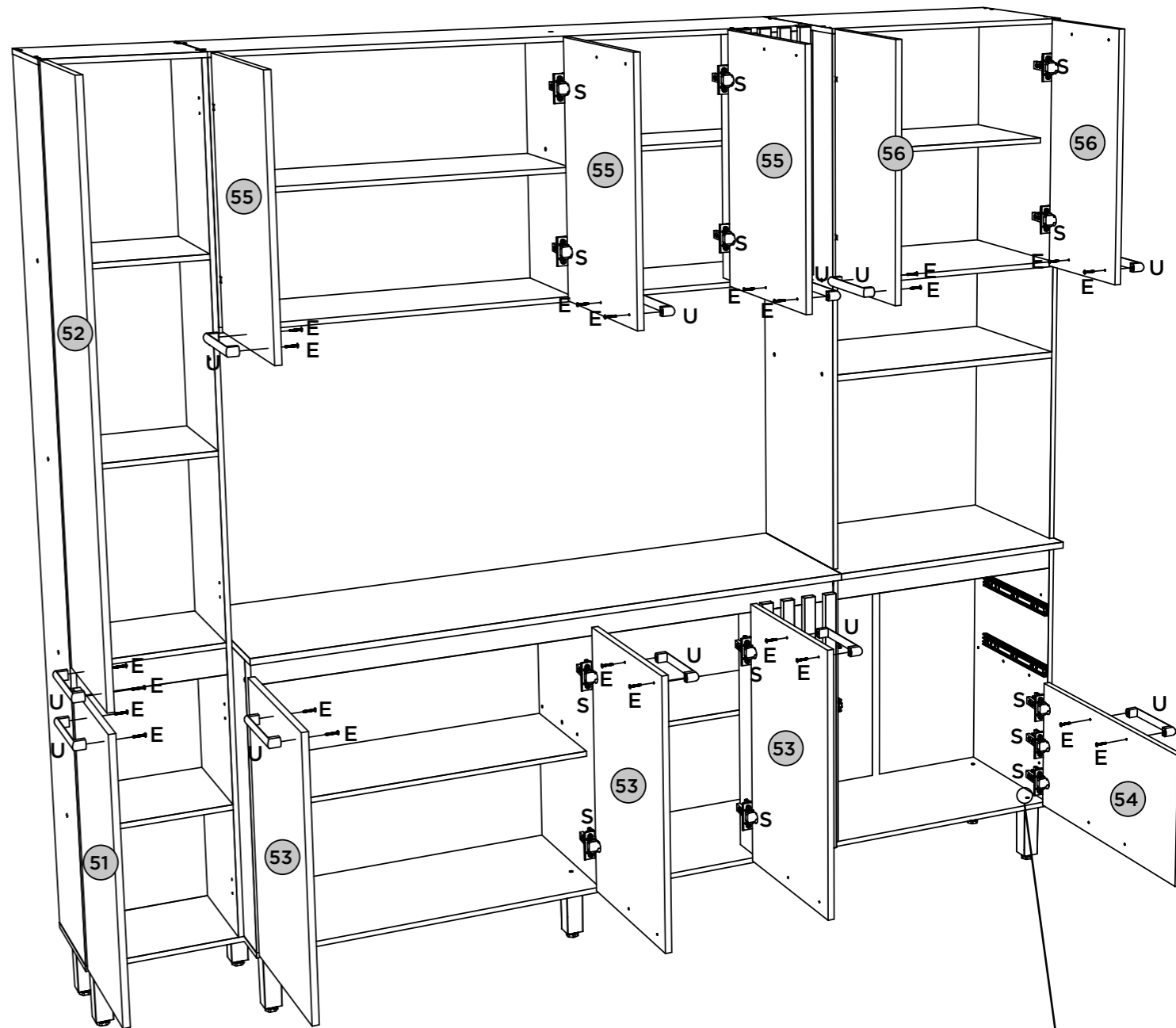
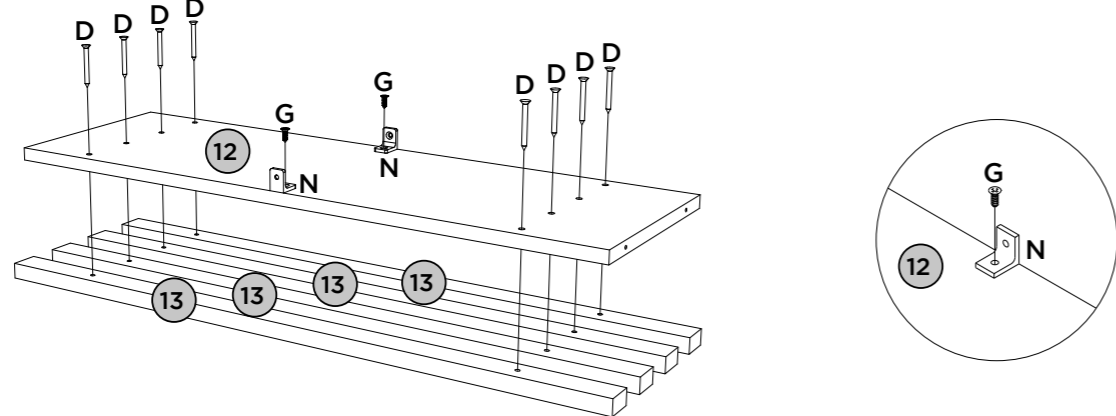
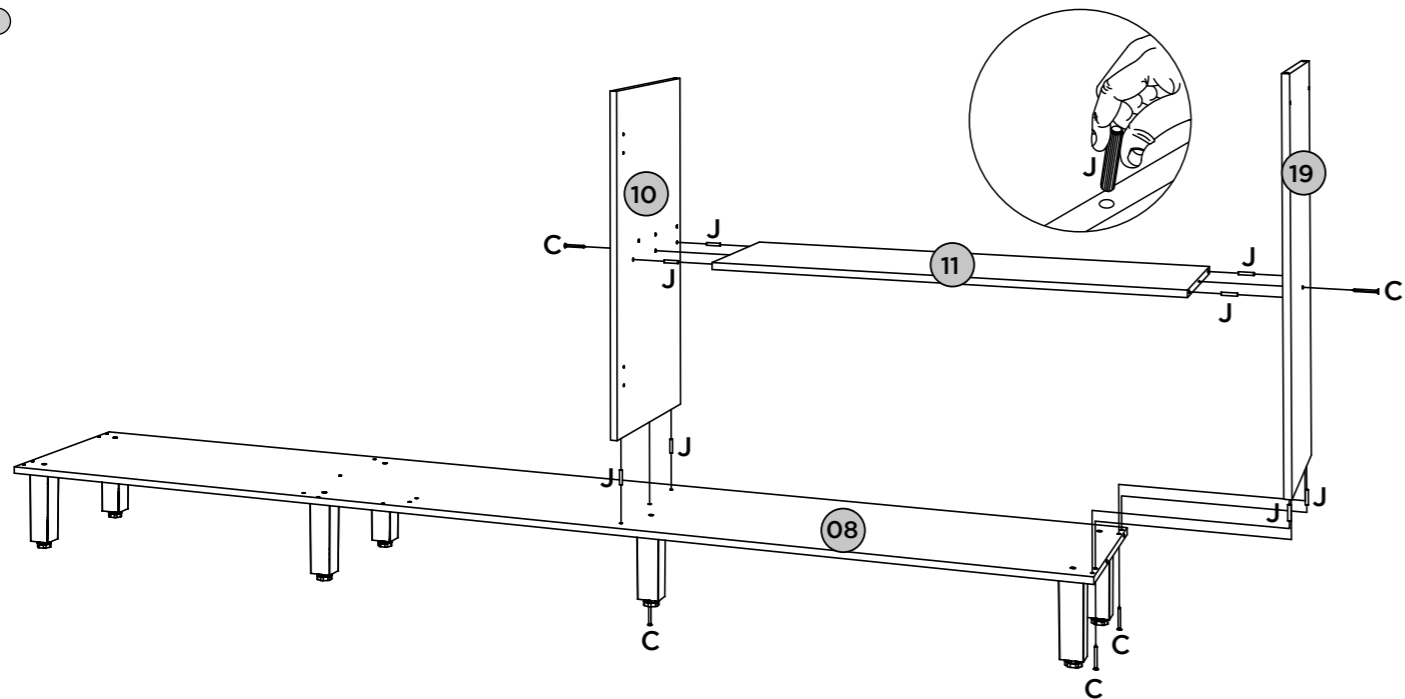
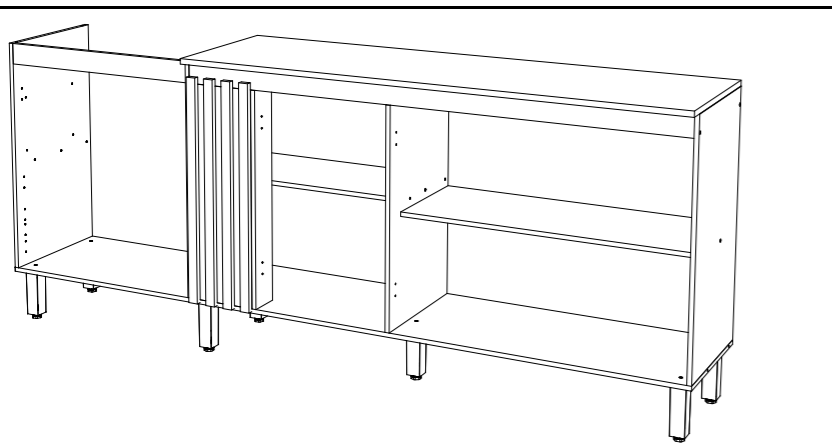
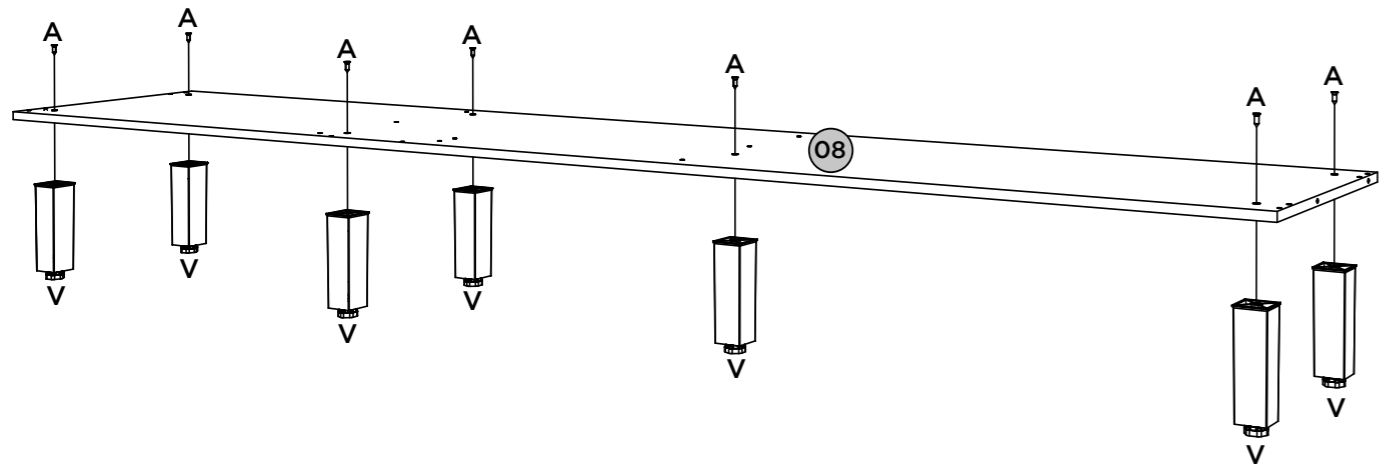

Video: Instalar e regular Dobradiças
 Video: Instale y ajuste las bisagras
 Video: Install and adjust hinges



Montagem das gavetas usada na opção 01 e 02

Montaje de cajones utilizados en la opción 01 y 02

Assembly of drawers used in option 01 and 02

2x
1º

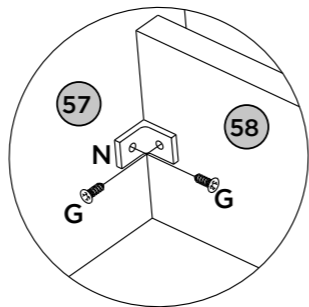
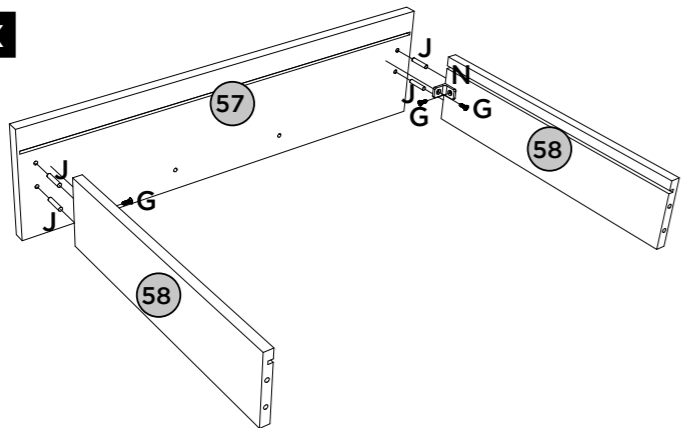

2x
2º

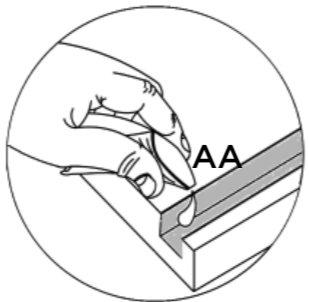
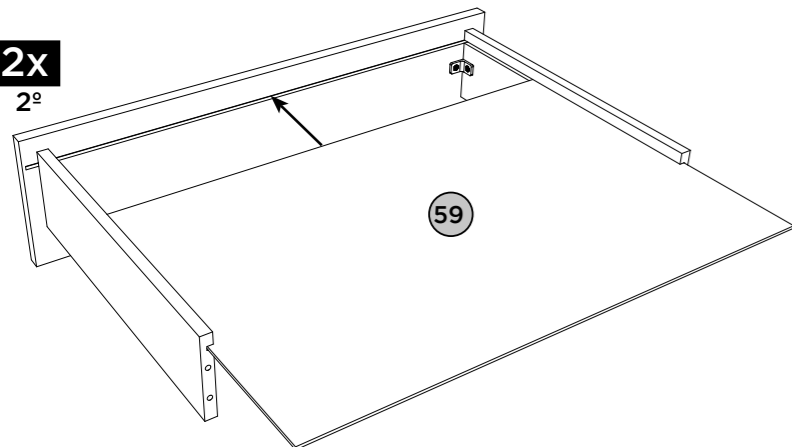

2x
3º

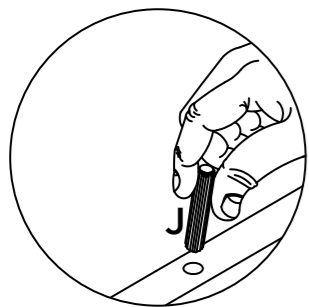
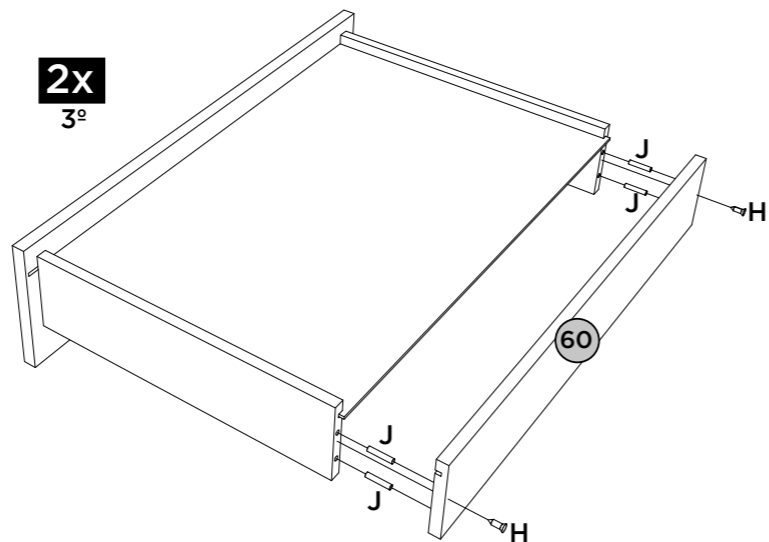

2x
4º

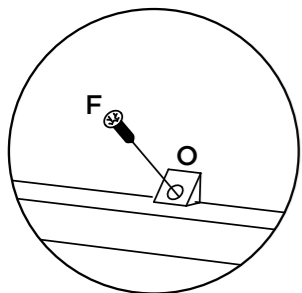
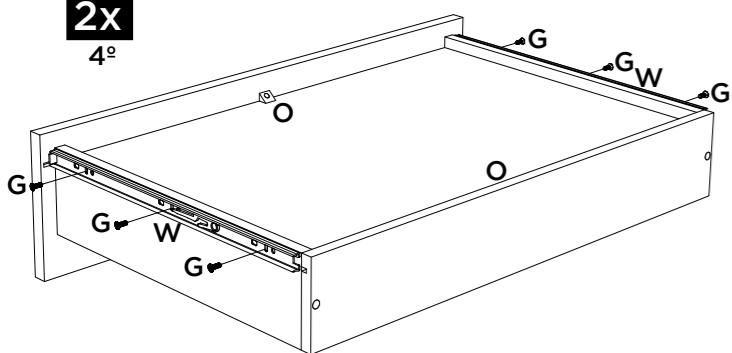

2x
5º

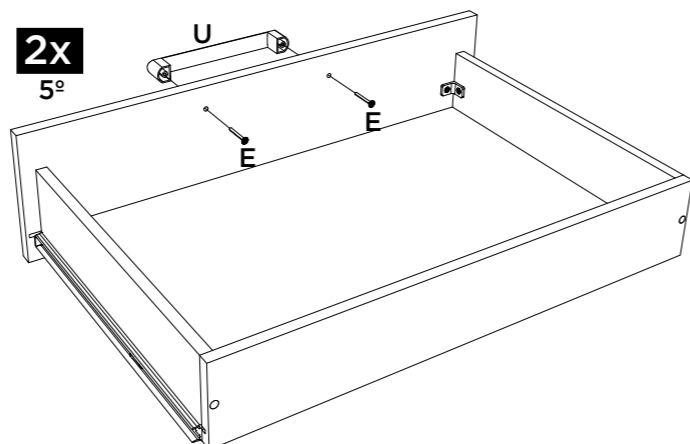

Montagens na opção 02

Se monta en la opción 02

Assemblies in option 02



1

